

Iris V1.1 Baseboard

Datasheet

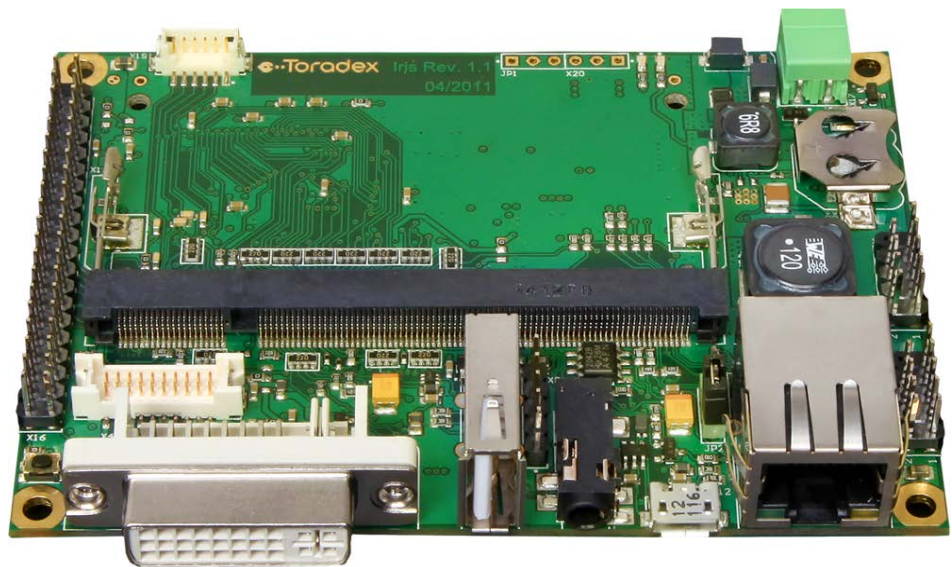

Revision History

Date	Doc. Rev.	Iris Version	Changes
20-Jan-11	Rev. 0.9	V1.0	Preliminary Release
24-Mar-11	Rev. 0.91	V1.0	FF RS-232 header (X13), chapter 2.2.9
10 –May-11	Rev. 1.0	V1.1	<p>Transition to Iris 1.1</p> <p>Various chapters: the Iris assembly image have been updated</p> <p>Chapter 2.1: the connector X5 has been eliminated, name changed for X18, X6 to JP1 and JP2 respectively.</p> <p>Chapter 2.2.3: “LVDS Power Jumper (X5)” eliminated. All the other chapters’ numbers have been updated accordingly.</p> <p>Chapter 2.2.3: Jumper name changed from X6 to JP2</p> <p>Chapter 2.2.4: the LVDS connector pin-out has been modified.</p> <p>Chapter 2.2.13: Jumper name changed from X18 to JP1</p> <p>Chapter 2.4.2: Pin-out changes in the connector X3</p> <p>Chapter 4: correction in the assembly option table</p>
15-Sep-11	Rev. 1.1	V1.1	<p>Chapter 2.2.13: SD boot assembly option information</p> <p>Chapter 4: SD boot assembly option information added to the table and to the picture</p> <p>Chapter 8: RoHS Compliance information added</p> <p>Various corrections</p>
14-Oct-11	Rev. 1.2	V1.1	<p>Chapter 1.2.3: correction in the maximum power provided by the 3.3V power rail</p> <p>Chapter 2.1: added the information about the RTC batteries supported</p>
14-Nov-11	Rev. 1.3	V1.1	Changed Disclaimer
09-Jan-13	Rev. 1.4	V1.1	Updated links to Toradex websites

Contents

1. Introduction.....	5
1.1. Reference Documents	5
1.1.1 Colibri Computer Modules.....	5
1.1.2 Colibri modules migration guide	Error! Bookmark not defined.
1.2. Features	5
1.2.1 Overview.....	5
1.2.2 Block Diagram	6
1.2.3 Power Supply	6
1.2.4 Installation	6
2. Iris Interfaces	7
2.1. Top Side Connectors: Physical Drawing.....	7
2.2. Top Side Connectors: Pin Assignments	8
2.2.1 Colibri SODIMM Connector (X1).....	8
2.2.2 DVI-I Connector (X4).....	8
2.2.3 Central Tab Jumper (JP2).....	9
2.2.4 LVDS Connector (X7).....	9
2.2.5 Audio Header (X9).....	10
2.2.6 USB Micro A/B (X12).....	10
2.2.7 USB Type A (X11).....	10
2.2.8 FF RS-232 header (X13).....	10
2.2.9 STD/BT RS-232 header (X14)	10
2.2.10 Ethernet connector (X15)	11
2.2.11 Extension Connector (X16)	11
2.2.12 Power Supply connector (X17).....	13
2.2.13 Boot Mode header (JP1)	13
2.2.14 Touch Connector (X19).....	13
2.3. Bottom Side Connectors: Physical Drawing	13
2.4. Bottom Side Connectors: Pin Assignment.....	14
2.4.1 DVI FFC connector (X2).....	14
2.4.2 RGB Connector (X3)	15
2.4.3 Micro SD Card Holder (X10)	16
2.5. LEDs.....	17
3. Functional.....	18
3.1. Display interfaces.....	18
4. Assembly Options.....	20
4.1. Iris Assembly Options - Top.....	20
4.2. Iris Assembly Options - Bottom.....	21

- 5. Mechanical Data 22
 - 5.1. Dimensions 22
 - 5.1.1 Iris Dimensions Top 22
 - 5.1.2 Iris Dimensions Bottom 23
- 6. Electrical Characteristics 24
- 7. PCB Versions 24
- 8. RoHS Compliance 24

1. Introduction

Iris is a carrier board for the Colibri family of computer-on-modules. Iris supports all modules in the Colibri product family, and includes support for the additional/enhanced functionality on the Colibri T20, the Toradex module which feature the NVIDIA® Tegra™ 2 processor.

1.1. Reference Documents

For detailed technical information about suitable computer modules, please refer to the documents listed below.

1.1.1 Colibri Computer Modules

An overview of the Colibri product family:

<http://www.toradex.com/products/colibri-arm-modules>

1.2. Features

1.2.1 Overview

Iris provides the following features and communication interfaces:

- USB Type-A and OTG Micro-AB connectors for host and host/client
- RJ45 Ethernet
- Micro SD card slot
- Digital (TDMS) and Analog (VGA) interfaces on a single DVI-I connector
- LVDS interface
- Digital RGB interface
- Audio out on 3.5mm stereo jack
- Microphone in and line in on audio header
- SSP, I2C, 4 ADCs, 4 PWMs and 8 GPIOs on header
- STD, BT and FF TTL level UART on header
- BT and FF RS-232 interfaces
- Real-time clock with battery backup
- Resistive touch screen connector

1.2.2 Block Diagram

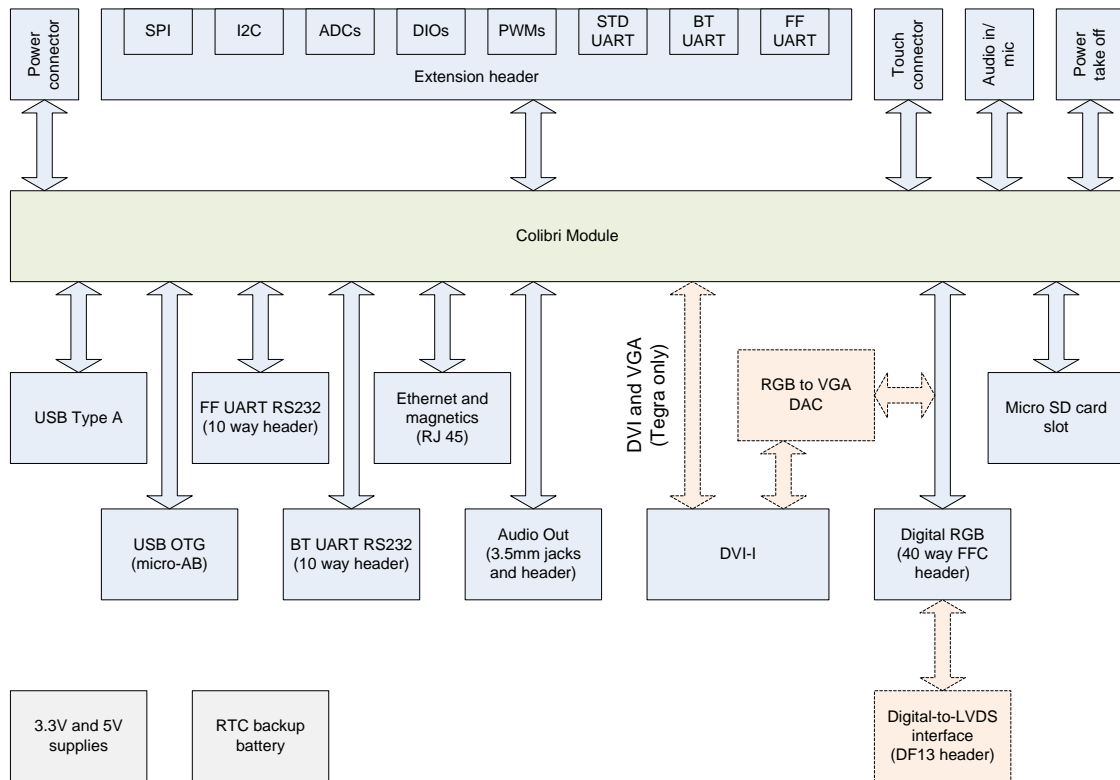

Fig.1 Iris Block Diagram

1.2.3 Power Supply

Iris has a wide input voltage range of 6-27V DC.

The on-board power supply provides the following supplies (maximum power).

5V / 3.5A	(17.5W)
3.3V / 2.5A	(8.25W)

The supply is protected against reverse input voltage polarity and short circuits.

1.2.4 Installation

Follow these steps for a quick start:

1. Insert a Colibri Module in the SODIMM socket X1 on Iris
2. Plug in a monitor on the corresponding connector X4, a keyboard and a mouse on the USB port
3. Connect an external power supply to the board by the X17 connector (6-27V, 3W min, depending on your peripherals)
4. The system will start as soon as the power supply is connected. Two LEDs will light to indicate the presence of the 3.3V and 5V voltage rails

Now the preinstalled operating system will boot.

For detailed documentation of the software as well as for the latest bootloader and software images please refer to the Colibri website:

<http://www.toradex.com/products/colibri-arm-modules>

2. Iris Interfaces

2.1. Top Side Connectors: Physical Drawing

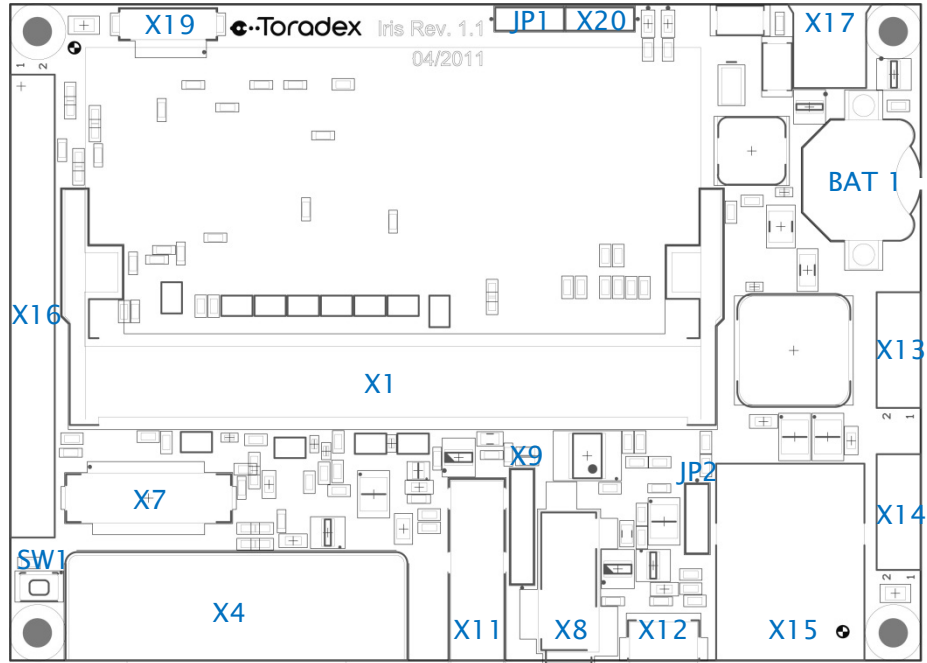

Fig.2 Iris connectors – Top Side

Ref	Description	Remarks
X1	Colibri SODIMM connector	
X4	DVI-I connector	
JP2	Central Tab jumper	
X7	LVDS connector	
X8	Audio Jack	
X9	Audio header	
X11	USB Type A	
X12	USB Micro A/B (Host/Device)	
X13	FF RS-232 header	
X14	STD/BT RS-232 header	
X15	Ethernet connector	
X16	Extension connector	
X17	Power Supply connector	
JP1	Boot Mode header	Not populated
X19	Touch connector	
X20	3.3/5V header	Not populated
BAT1	12mm Battery holder	Supported batteries: BR1216, CR1216, BR1220, CL1220, CR1220, BR1225
SW1	Reset Button	

2.2. Top Side Connectors: Pin Assignments

2.2.1 Colibri SODIMM Connector (X1)

Type: SODIMM 200 Socket.

Manufacturer: Tyco Electronics-1473005-1.

For the pin out of the Colibri module please refer to the Colibri Datasheet.

2.2.2 DVI-I Connector (X4)

Pin	Description
1	TMDS_DATA2_N
2	TMDS_DATA2_P
3	GND
4	NC
5	NC
6	DDC_CLK
7	DDC_DATA
8	CRT_VSYNC
9	TMDS_DATA1_N
10	TMDS_DATA1_P
11	GND
12	NC
13	NC
14	+5V
15	GND
16	HOTPLUG_DETECT
17	TMDS_DATA0_N
18	TMDS_DATA0_P
19	GND
20	NC
21	NC
22	GND
23	TMDS_CLK_P
24	TMDS_CLK_N
C1	CRT_RED
C2	CRT_GREEN
C3	CRT_BLUE
C4	CRT_HSYNC
C5	AGND

2.2.3 Central Tab Jumper (JP2)

Jumper JP2 should be configured based upon the Ethernet controller which is present on the installed Colibri module.

Jumper position	Description
1-2	Use this configuration for DM9000E on PXA270
2-3	Use this configuration for DM9000A/ASIX on other modules

2.2.4 LVDS Connector (X7)

Connector type: DF13A-20DP-1.25v(56)

Pin	Signal Name	Description
1	LVDS_5V	5V power supply pin
2	LVDS_3.3V	3.3V power supply pin
3	GND	
4	SEL1	Connected to LVDS_3.3V or GND via assembly option. The default assembly is GND
5	LVDS_OUT0_N	The negative LVDS output number 0
6	GND	
7	LVDS_OUT0_P	The positive LVDS output number 0
8	LVDS_OUT1_N	The negative LVDS output number 1
9	GND	
10	LVDS_OUT1_P	The positive LVDS output number 1
11	LVDS_OUT2_N	The negative LVDS output number 2
12	GND	
13	LVDS_OUT2_P	The positive LVDS output number 2
14	LVDS_CLK_N	The negative LVDS clock signal
15	GND	
16	LVDS_CLK_P	The positive LVDS clock signal
17	BL_ON	Back Light control signal
18	GND	
19	SEL2	Connected to LVDS_5V, LVDS_3.3V or GND via assembly option. The default assembly is 5V
20	SEL3	Connected to LVDS_3.3V or GND via assembly option. The default assembly is LVDS_3.3V

Remarks:

- The Signals SEL1, SEL2, SEL3 can be configured to be connected to LVDS_5V, LVDS_3.3V or GND. By default the resistors R37, R42 and R44 have been populated. For the location of these resistors please refer to the section 4.
- Please use the pins 1 and 2 as power supply pins (max 0.9A) and the SEL1, SEL2, SEL3 as setting pins.

2.2.5 Audio Header (X9)

Connector type: 1x5 Pin Header Male, 2.54mm

Pin	Description
1	Audio AVCC
2	Microphone IN
3	Line IN R
4	Line IN L
5	Audio AGND

2.2.6 USB Micro A/B (X12)

Pin	Description	Voltage	Remarks
1	V BUS USB FILT	+5V	
2	USB N		
3	USB P		
4	USB ID CON		
5	GND		

Remarks:

- This USB connector can be used for host and client

2.2.7 USB Type A (X11)

The USB interface is able to support USB 2.0 high speed and operate at a maximum 480Mbit/s, depending upon the Colibri module being used.

Pin	Description	Voltage
1	VCC USB	+5V
2	USB N	
3	USB P	
4	GND	

2.2.8 FF RS-232 header (X13)

The Full Function (FF) RS-232 connector is a 10 way (2 rows x 5 way) 2.54mm pitch header capable of being connected to an industry standard DTK/INTEL 10 way IDC to 9 way D-type male connector.

Pin	Signal Name
1	RS232_A_DCD
2	RS232_A_DSR
3	RS232_A_RXD
4	RS232_A_RTS
5	RS232_A_TXD
6	RS232_A_CTS
7	RS232_A_DTR
8	RS232_A_RI
9	GND
10	NC

2.2.9 STD/BT RS-232 header (X14)

Connector type: 2 rows x 5 way Pin Header Male, 2.54mm

Pin	Signal Name
1	RS232_C_RXD
2	NC
3	RS232_B_RXD
4	RS232_B_RTS
5	RS232_B_TXD
6	RS232_B_CTS
7	RS232_C_TXD
8	NC
9	GND
10	NC

Remarks:

- The RS232 serial transceivers can be shut down via two GPIOs which have been connected to the ForceOFF# pin. This is needed in order to use the RS232 signals that are on the extension connector at logic level. The following table shows the SODIMM pin assignment of the GPIOs reserved for this purpose:

SODIMM Pin Number	Disabled Header
102	X13
104	X14

2.2.10 Ethernet connector (X15)

Connector type: RJ-45

Pin	Signal Name	I/O Type	Voltage	Pull-up/Pull-down
1	ETH_TX0_P	O	+3.3V	50R to ETH_AVCC
2	ETH_TX0_N	O	+3.3V	50R to ETH_AVCC
3	ETH_RXI_P	I	+3.3V	
4	ETH_AVCC (CT_TXD)	PWR		
5	ETH_AGND (CT_RXD)	PWR		
6	ETH_RXI_N	I	+3.3V	
7	NC			
8	SHIELD			
9	+3.3V	PWR		
10	ETH_LINK_ACT	I	+3.3V	
11	ETH_SPEED	I	+3.3V	
12	+3.3V	PWR		
S1	SHIELD			
S2	SHIELD			

2.2.11 Extension Connector (X16)

Connector type: 2x20 Pin Header Male, 2.54mm

Pin	Signal Name	I/O Type	Voltage	Pull-up/Pull-down
1	RESET_EXT#	I	+3.3V	
2	GND	PWR		
3	GND	PWR		
4	RESET_OUT#	O	+3.3V	
5	I2C_SDA	I/O	+3.3V	4.7K to 3.3V
6	I2C_SCL	I/O	+3.3V	4.7K to 3.3V
7	GND	PWR		
8	SSPCLK	I/O	+3.3V	
9	SSPFRM	I/O	+3.3V	
10	SSPRXD	I	+3.3V	
11	SSPTXD	O	+3.3V	
12	+5V	PWR	+5V	
13	PIN_98 (GPIO)	I/O	+3.3V	
14	PIN_133 (GPIO)	I/O	+3.3V	
15	PIN_103 (GPIO)	I/O	+3.3V	
16	PIN_101 (GPIO)	I/O	+3.3V	
17	PIN_97 (GPIO)	I/O	+3.3V	
18	PIN_85 (GPIO)	I/O	+3.3V	
19	PIN_79 (GPIO)	I/O	+3.3V	
20	PIN_45 (GPIO)	I/O	+3.3V	
21	GND	PWR		
22	ANALOG_IN3	I	+3.3V	
23	ANALOG_IN2	I	+3.3V	
24	ANALOG_IN1	I	+3.3V	
25	ANALOG_IN0	I	+3.3V	
26	AUDIO_AGND	PWR		
27	UART_A_TXD	O	+3.3V	
28	UART_A_RXD	I	+3.3V	
29	UART_B_CTS	I	+3.3V	
30	UART_B_RTS	O	+3.3V	
31	UART_B_RXD	I	+3.3V	
32	UART_B_TXD	O	+3.3V	
33	+3.3V	PWR	+3.3V	
34	UART_C_RXD	I	+3.3V	
35	UART_C_TXD	O	+3.3V	
36	GND	PWR		
37	PWM_A	O	+3.3V	
38	PWM_B	O	+3.3V	
39	PWM_C	O	+3.3V	
40	PWM_D	O	+3.3V	

Remarks:

- The PWM_A signal has also been routed to the RGB display connector (X3) to provide backlight brightness control for connected LCD displays; for this reason a populated zero ohm

resistor (R84) has been placed before connector X16. Please refer to the section 4 for the position of R84.

- Since the Colibri PXA3XX does not support the PWM_D signal, pin 152 of the SODIMM connector has been connected to the PWM_D line through a not assembled 0ohm resistor (R110). Please refer to the section 4 for the position of R110.
- The signal ANALOG_IN3 is also used as the TOUCH_WIPER signal for the Touch (X19) and the RGB connector (X3). For this reason a populated 0ohm resistor (R88) has been placed between the signals ANALOG_IN3 and TOUCH_WIPER. This resistor can be removed in the event the fourth analog signal is required and the TOUCH_WIPER signal (for 5 wire resistive touch screen panels) is not. Please refer to the section 4 for the position of R88.

2.2.12 Power Supply connector (X17)

Connector type: Tyco 284512-2

Pin	Description	Voltage / range
1	GND_IN	
2	PWR_IN	6 – 27V

2.2.13 Boot Mode header (JP1)

This is an unpopulated 2.54mm pin which provides the signals required to boot the Colibri T20 module into recovery mode (this is not functional on the Colibri PXAxxx modules). The pin assignment is described in the following table:

Pin	Signal Name	Remarks
1	RECOVERY	By shorting the pin 1-2 the Colibri will boot in Recovery boot mode.
2	GND	
3	SD_BOOT	By shorting the pin 2-3 the Colibri will boot in SD boot mode.

Remarks:

- In order to use the SD Boot (only with Colibri T20) the resistors R109, R111, R112 and R113 need to be populated with a value of 100 R. For the location of these resistors please refer to the section 4.

2.2.14 Touch Connector (X19)

Connector type: Hirose DF13C-6P-1.25V(51)

Pin	Signal Name
1	GND
2	TOUCH_TSMY
3	TOUCH_TSPY
4	TOUCH_TSMX
5	TOUCH_TSPX
6	TOUCH_WIPER

Remarks:

- For further information about the 5-wire resistive touch interface, please refer to our developer site:

<http://developer.toradex.com/knowledge-base/5-wire-resistive-touch-interface>

2.3. Bottom Side Connectors: Physical Drawing

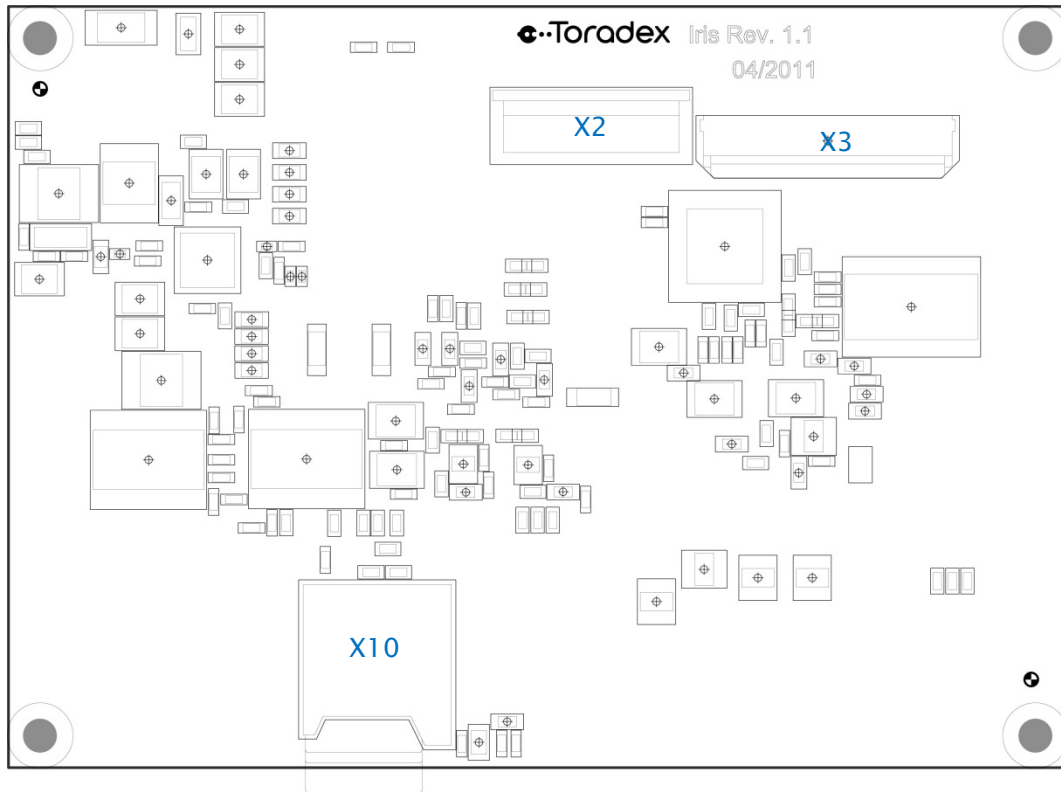

Fig.3 Iris connectors – Bottom Side

Ref.	Description	Remarks
X2	DVI FFC connector	
X3	RGB connector	
X10	Micro SD Card Holder	

2.4. Bottom Side Connectors: Pin Assignment

2.4.1 DVI FFC connector (X2)

Connector type: Molex 52435-2471

Pin	Signal Name	I/O Type	Voltage	Pull-up/Pull-down
1	GND	PWR		
2	TMDS_CLK_P	I	+3.3V	
3	TMDS_CLK_N	I	+3.3V	
4	GND	PWR		
5	TMDS_DATA0_P	I	+3.3V	
6	TMDS_DATA0_N	I	+3.3V	
7	GND	PWR		
8	TMDS_DATA1_P	I	+3.3V	
9	TMDS_DATA1_N	I	+3.3V	
10	GND	PWR		
11	TMDS_DATA2_P	I	+3.3V	
12	TMDS_DATA2_N	I	+3.3V	
13	NC			

14	HOTPLUG_DETECT	O	+3.3V	
15	DDC_CLK	I	+5V	1.8KR to +5V
16	DDC_DATA	I	+5V	1.8KR to +5V
17	GND	PWR		
18	CRT_RED	I	+3.3V	
19	GND	PWR		
20	CRT_GREEN	I	+3.3V	
21	GND	PWR		
22	CRT_BLUE	I	+3.3V	
23	CRT_VSYNC	I	+3.3V	
24	CRT_HSYNC	I	+3.3V	

2.4.2 RGB Connector (X3)

The RGB display interface uses the unified display interface pin out, for which there are a wide variety of displays of different sizes and resolutions available which will connect directly via a 40 way FFC.

Connector type: Omron XF2M-4015-1A

Pin	Signal Name	I/O Type	Voltage	Pull-up/Pull-down
1	GND	PWR		
2	GND	PWR		
3	+3.3V	PWR	+3.3V	
4	+3.3V	PWR	+3.3V	
5	BL_ON	O	+3.3V	
6	PWM_A	O	+3.3V	
7	RESET_OUT#	O	+3.3V	
8	LCD_D_5	O	+3.3V	
9	LCD_D_4	O	+3.3V	
10	LCD_D_3	O	+3.3V	
11	LCD_D_2	O	+3.3V	
12	LCD_D_1	O	+3.3V	
13	LCD_D_0	O	+3.3V	
14	GND	PWR		
15	LCD_D_11	O	+3.3V	
16	LCD_D_10	O	+3.3V	
17	LCD_D_9	O	+3.3V	
18	LCD_D_8	O	+3.3V	
19	LCD_D_7	O	+3.3V	
20	LCD_D_6	O	+3.3V	
21	GND	PWR		
22	LCD_D_17	O	+3.3V	
23	LCD_D_16	O	+3.3V	
24	LCD_D_15	O	+3.3V	
25	LCD_D_14	O	+3.3V	
26	LCD_D_13	O	+3.3V	
27	LCD_D_12	O	+3.3V	
28	LCD_PCLK_WR	O	+3.3V	

29	GND	PWR	
30	LCD_LCLK_A0	O	+3.3V
31	LCD_FCLK_RD	O	+3.3V
32	LCD_BIAS	O	+3.3V
33	Connected to 3.3V or GND via assembly option. The default assembly is GND	O	+3.3V/GND
34	Connected to 3.3V or GND via assembly option. The default assembly is GND	O	+3.3V/GND
35	GND	PWR	
36	+3.3V	PWR	+3.3V
37	TOUCH_TSPY	O	+3.3V
38	TOUCH_TSMX	O	+3.3V
39	TOUCH_TSMY	O	+3.3V
40	TOUCH_TSPX	O	+3.3V

2.4.3 Micro SD Card Holder (X10)

Pin	Signal Name	I/O Type	Voltage	Pull-up/Pull-down
1	MM_DAT_2	I/O	+3.3V	68k to +3.3V
2	MM_DAT_3	I/O	+3.3V	68k to +3.3V
3	MM_CMD	I	+3.3V	33K to +3.3V
4	+3.3V	PWR	+3.3V	
5	MM_CLK	I	+3.3V	
6	GND	PWR		
7	MM_DAT_0	I/O	+3.3V	68k to +3.3V
8	MM_DAT_1	I/O	+3.3V	68k to +3.3V
CD1/2	MM_CD			
S1/2	SHIELD			

2.5. LEDs

There are two LEDs on the top side of the PCB; they are tuned on if the power supply circuit is correctly providing 3.3 and 5V power rails.

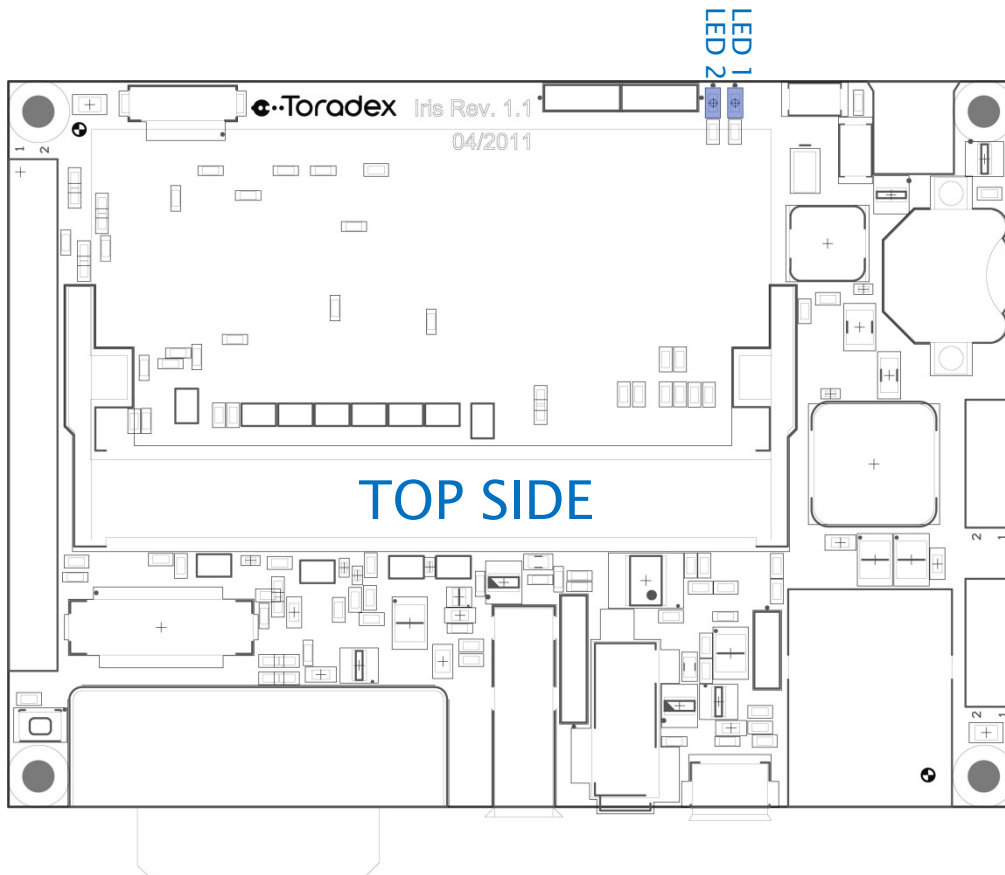

Fig.4 LED Positions

Ref.	Description
LED1	3.3V
LED2	5V

3. Functional

3.1. Display interfaces

There are many options for connecting LCD panels and monitors, with the following three interfaces supported:

- 18 bit digital RGB
- LVDS
- DVI-I (Digital TDMS and Analog VGA)

The following image shows the Display interface architecture that has been implemented on Iris

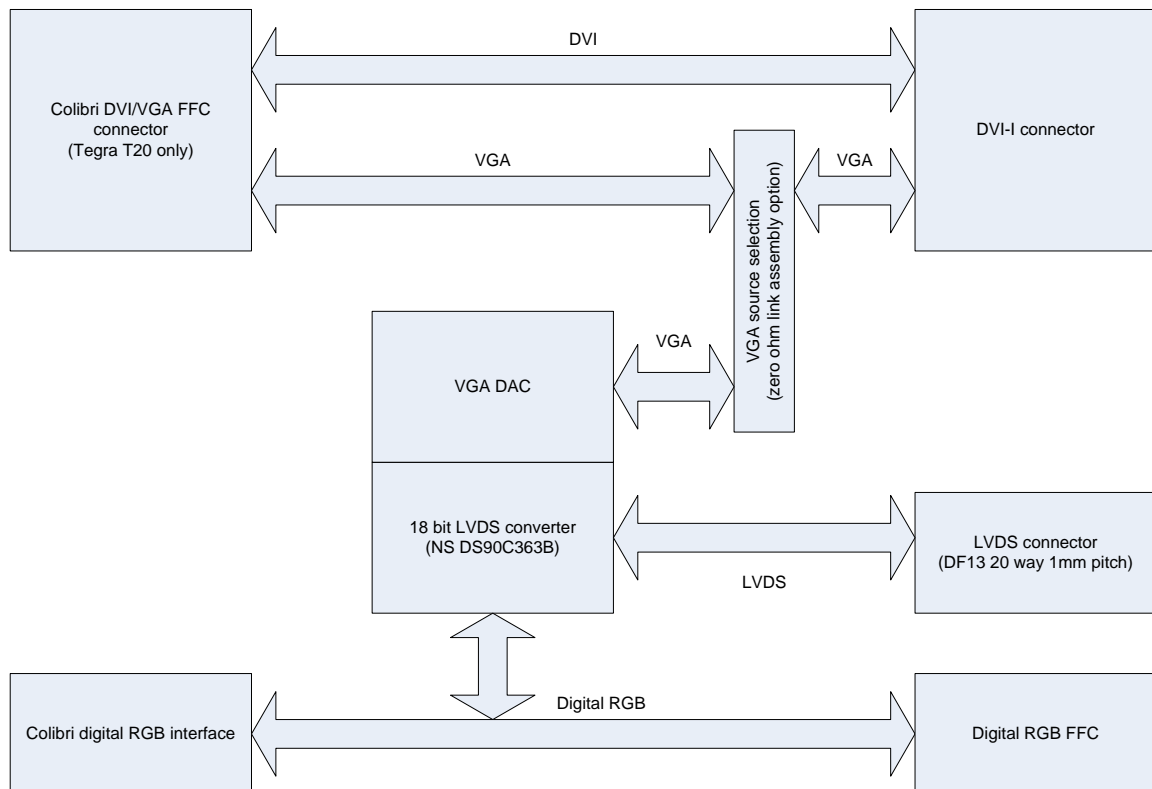

Fig.5 Display Interface Architecture

The combination of display interfaces which are available are dependent upon the Colibri module which is installed:

- The Colibri T20 is able to drive two independent displays on the following combination of display interfaces:
 - DVI and VGA
 - DVI and LVDS
 - DVI and RGB

- The Colibri PXAxxx are able to drive single display on the following display interfaces:
 - RGB
 - LVDS
 - VGA

It is possible to select, using an assembly option, whether the VGA output from the Colibri T20 FFC or VGA DAC (generated from the RGB interface) is connected to the analogue VGA of the DVI-I interface.

The following table describes these assembly options:

Solution Selected	Resistors to assemble
Use the internal RGB to VGA	R14, R15, R16, R19, R20
Use the Colibri T20 FFC VGA signals	R17, R18, R21, R22, R23

The default configuration connects the output of the on-board VGA DAC to the DVI-I connector. Please refer to section 4 for resistor locations.

4. Assembly Options

This section describes the assembly options that can be used to configure different features and functional options.

The following table lists all the assembly options that have been described in the previous pages of this document.

Solution Selected	Assembly option	Section n.	PCB side
SEL1 to LVDS_3.3V	Disassemble R44 and assemble R40	2.2.4	Top
SEL2 to LVDS_3.3V	Disassemble R37 and assemble R41	2.2.4	Top
SEL2 to GND	Disassemble R37 and assemble R45	2.2.4	Top
SEL3 to GND	Disassemble R46 and assemble R42	2.2.4	Top
PWM_A not used for the RGB connector	Disassemble the resistor R84	2.2.11	Top
ANALOG_IN3	Disassemble the resistor R88	2.2.11	Top
PWM_D for PXA3XX modules	Assemble the resistor R110	2.2.11	Bottom
Use the internal RGB to VGA	R14, R15, R16, R19, R20	3.1	Bottom
Use the Colibri T20 FFC VGA signals	R17, R18, R21, R22, R23	3.1	Bottom
SD Boot (only with Colibri T20)	Assemble 100 Ω resistors R109, R111, R112, R113	2.2.13	Bottom

4.1. Iris Assembly Options - Top

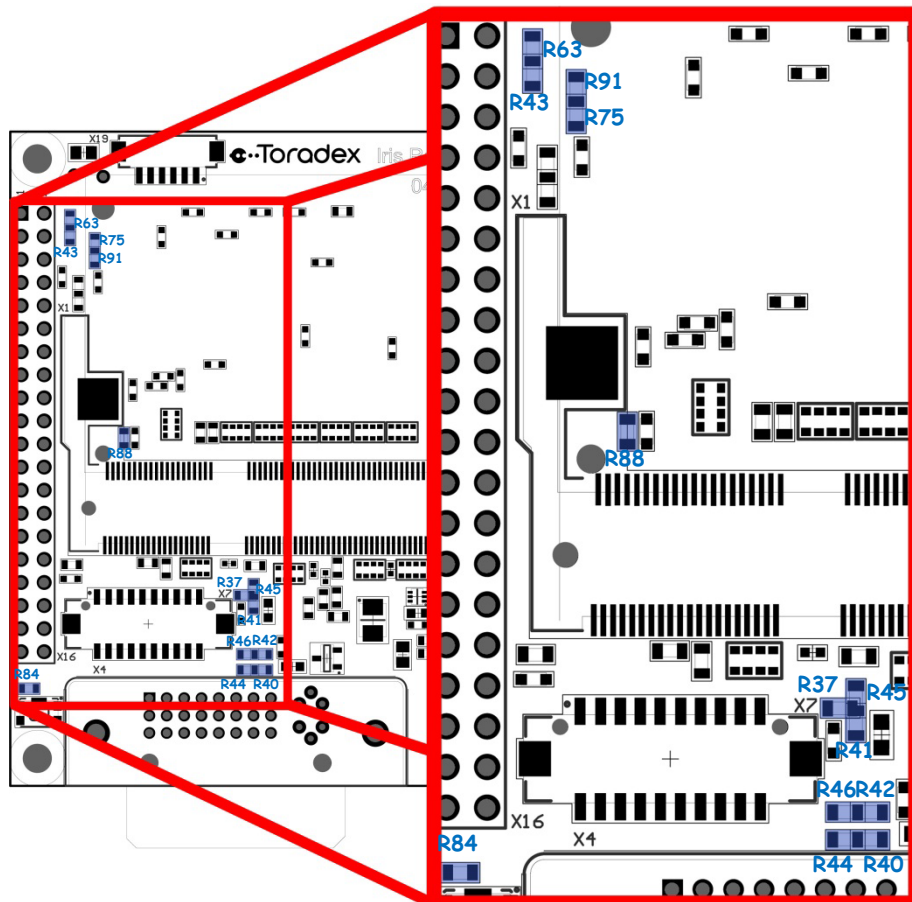

Fig.6 Iris Assembly Options – Top Side

4.2. Iris Assembly Options - Bottom

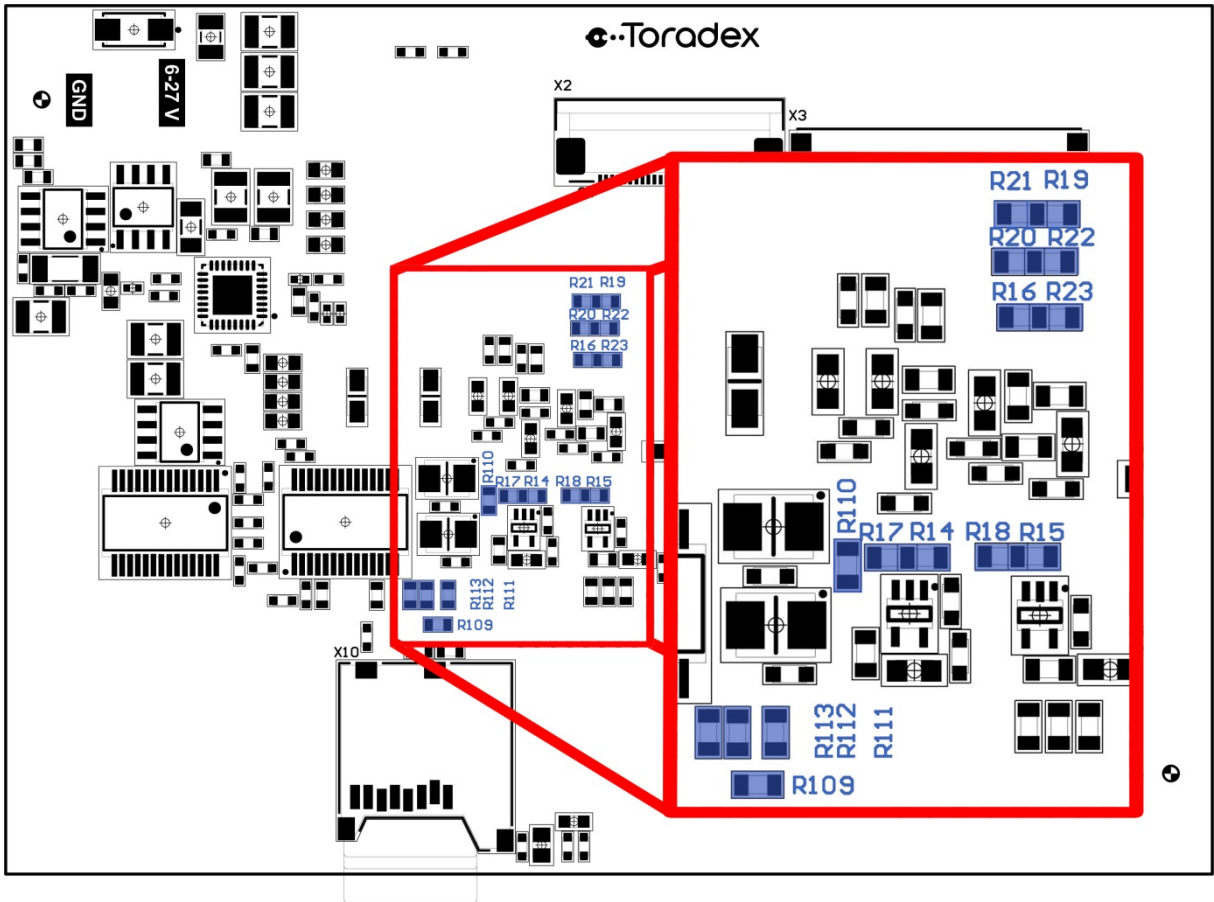

Fig.7 Iris Assembly Options – Bottom Side

5.1.2 Iris Dimensions Bottom

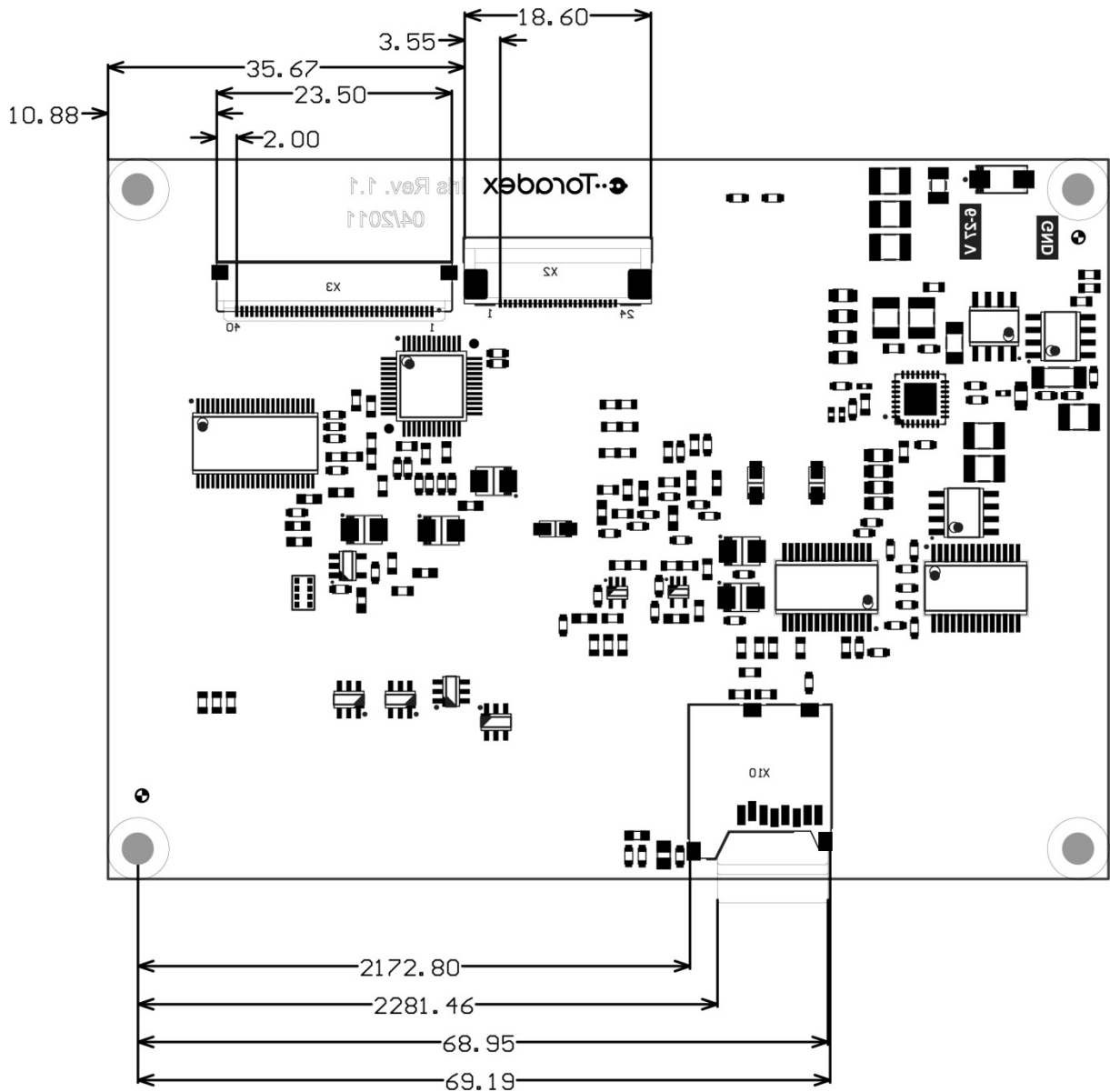

Fig.9 Iris Dimensions – Bottom Side

6. Electrical Characteristics

Symbol	Description	Min	Typ	Max	Unit
PWR_IN	Main power supply voltage	6	24	27	V
GND_IN	Main power supply current	0		6	A
V_BACKUP	Optional RTC battery voltage	2.3	3	3.6	V
I_(+5V)	total current for external devices at +5v rail: X16 Pin 12 X20 Pin 1 USB connectors / USB header			2.5	A
I_(+3.3V)	total current for external devices at +3.3V: X16 Pin 33 X20 Pin 3			1.5	A
I_Pin(X16)	Current for a single power pin of connector X16			0.5	A
I_Pin(X20)	Current for a single power pin of connector X20			0.5	A
I_Pin(X11)	Current for a single power pin of connector X11			0.5	A
I_Pin(X12)	Current for a single power pin of connector X12			0.5	A
I_Pin(X16)	Current for a single power pin of connector X16			1	A
I_Pin(X20)	Current for a single power pin of connector X20			1	A

7. PCB Versions

Revision history of the Iris PCB is as follows:

- Iris V1.0: Initial design
- Iris V1.1

From the version 1.0 to 1.1 the following changes have been made:

- The connector X5 has been eliminated
- The LVDS connector pin-out has been modified in order to have the BL_ON signal on it and in order to have more power supply and settings (SEL1, SEL2, SEL3) combination
- The connector X3 pin-out has been modified in order to solve some compatibility issues that are present across the unified family interface LCD panels
- The connectors X18 and X6 have been renamed respectively with JP1 and JP2
- The diode D9 has been eliminated (shorted)
- The 5V reference voltage for the DVI-I ESD protection diodes has been disconnected
- The pull-up resistors for the DDC_DATA and DDC_CLOCK signals have been connected to a voltage line protected against back-feeding.

8. RoHS Compliance

The Iris baseboard complies with the European Union's Directive 2002/95/EC: "Restrictions of Hazardous Substances".

Disclaimer:

Copyright © Toradex AG. All rights reserved. All data is for information purposes only and not guaranteed for legal purposes. Information has been carefully checked and is believed to be accurate; however, no responsibility is assumed for inaccuracies.

Brand and product names are trademarks or registered trademarks of their respective owners.

Specifications are subject to change without notice.