



NEXCOM International Co., Ltd.

Network and Communication Solutions

Industrial-Grade Platform

ISA 140

User Manual

CONTENTS

Preface

Copyright	iv
Disclaimer	iv
Acknowledgements	iv
Regulatory Compliance Statements	iv
Declaration of Conformity	iv
RoHS Compliance	v
Warranty and RMA	vi
Safety Information	viii
Installation Recommendations	viii
Safety Precautions	ix
Technical Support and Assistance	x
Conventions Used in this Manual	x
Global Service Contact Information	xi
Package Contents	xiii
Ordering Information	xiv

Chapter 1: Product Introduction

Overview	1
Key Features	1
Hardware Specifications	2
Knowing Your ISA 140	3
Mechanical Dimensions	4

Chapter 2: Jumpers and Connectors

Before You Begin	5
Precautions	5
Jumper Settings	6
Locations of the Jumpers and Connectors	7
Jumpers	9
CMOS Clear	9
Connector type: 1x3 3-pin header, 2.54mm pitch	9
Programmable for MCU	9
Connector Pin Definitions	10
External I/O Interfaces	10
USB3.0	10
HDMI Connector	10
Internal Connectors	11
M.2 B-Key SATA	11
M.2 B-Key LTE	11
Mini PCIe Slot	12
Power and Reset	12
Micro SIM Connector	13
Block Diagram	14

Chapter 3: System Setup

Removing the Bottom Chassis Cover	15
Installing an M.2 SSD Storage Module	16
Installing SO-DIMM Memory Modules	18



Installing a Wireless LAN Module 19
Installing a LTE Module 21
Installing a SIM Card 23

Chapter 4: BIOS Setup

About BIOS Setup 24
When to Configure the BIOS..... 24
Default Configuration 25
Entering Setup 25
Legends 25
BIOS Setup Utility 27
 Main 27
 Advanced 28
 Chipset..... 37
 Security 41
 Boot..... 42
 Save & Exit 43



PREFACE

Copyright

This publication, including all photographs, illustrations and software, is protected under international copyright laws, with all rights reserved. No part of this manual may be reproduced, copied, translated or transmitted in any form or by any means without the prior written consent from NEXCOM International Co., Ltd.

Disclaimer

The information in this document is subject to change without prior notice and does not represent commitment from NEXCOM International Co., Ltd. However, users may update their knowledge of any product in use by constantly checking its manual posted on our website: <http://www.nexcom.com>. NEXCOM shall not be liable for direct, indirect, special, incidental, or consequential damages arising out of the use of any product, nor for any infringements upon the rights of third parties, which may result from such use. Any implied warranties of merchantability or fitness for any particular purpose is also disclaimed.

Acknowledgements

ISA 140 is a trademark of NEXCOM International Co., Ltd. All other product names mentioned herein are registered trademarks of their respective owners.

Regulatory Compliance Statements

This section provides the FCC compliance statement for Class A devices and describes how to keep the system CE compliant.

Declaration of Conformity

FCC

This equipment has been tested and verified to comply with the limits for a Class A digital device, pursuant to Part 15 of FCC Rules. These limits are designed to provide reasonable protection against harmful interference when the equipment is operated in a commercial environment. This equipment generates, uses, and can radiate radio frequency energy and, if not installed and used in accordance with the instructions, may cause harmful interference to radio communications. Operation of this equipment in a residential area (domestic environment) is likely to cause harmful interference, in which case the user will be required to correct the interference (take adequate measures) at their own expense.

CE

The product(s) described in this manual complies with all applicable European Union (CE) directives if it has a CE marking. For computer systems to remain CE compliant, only CE-compliant parts may be used. Maintaining CE compliance also requires proper cable and cabling techniques.

RoHS Compliance



NEXCOM RoHS Environmental Policy and Status Update

NEXCOM is a global citizen for building the digital infrastructure. We are committed to providing green products and services, which are compliant with European Union RoHS (Restriction on Use of Hazardous Substance in Electronic Equipment) directive 2011/65/EU, to be your trusted green partner and to protect our environment.

RoHS restricts the use of Lead (Pb) < 0.1% or 1,000ppm, Mercury (Hg) < 0.1% or 1,000ppm, Cadmium (Cd) < 0.01% or 100ppm, Hexavalent Chromium (Cr6+) < 0.1% or 1,000ppm, Polybrominated biphenyls (PBB) < 0.1% or 1,000ppm, and Polybrominated diphenyl Ethers (PBDE) < 0.1% or 1,000ppm.

In order to meet the RoHS compliant directives, NEXCOM has established an engineering and manufacturing task force in to implement the introduction of green products. The task force will ensure that we follow the standard NEXCOM development procedure and that all the new RoHS components and new manufacturing processes maintain the highest industry quality levels for which NEXCOM are renowned.

The model selection criteria will be based on market demand. Vendors and suppliers will ensure that all designed components will be RoHS compliant.

How to recognize NEXCOM RoHS Products?

For existing products where there are non-RoHS and RoHS versions, the suffix "(LF)" will be added to the compliant product name.

All new product models launched after January 2013 will be RoHS compliant. They will use the usual NEXCOM naming convention.

Warranty and RMA

NEXCOM Warranty Period

NEXCOM manufactures products that are new or equivalent to new in accordance with industry standard. NEXCOM warrants that products will be free from defect in material and workmanship for 2 years, beginning on the date of invoice by NEXCOM. HCP series products (Blade Server) which are manufactured by NEXCOM are covered by a three year warranty period.

NEXCOM Return Merchandise Authorization (RMA)

- Customers shall enclose the “NEXCOM RMA Service Form” with the returned packages.
- Customers must collect all the information about the problems encountered and note anything abnormal or, print out any on-screen messages, and describe the problems on the “NEXCOM RMA Service Form” for the RMA number apply process.
- Customers can send back the faulty products with or without accessories (manuals, cable, etc.) and any components from the card, such as CPU and RAM. If the components were suspected as part of the problems, please note clearly which components are included. Otherwise, NEXCOM is not responsible for the devices/parts.
- Customers are responsible for the safe packaging of defective products, making sure it is durable enough to be resistant against further damage and deterioration during transportation. In case of damages occurred during transportation, the repair is treated as “Out of Warranty.”
- Any products returned by NEXCOM to other locations besides the customers’ site will bear an extra charge and will be billed to the customer.

Repair Service Charges for Out-of-Warranty Products

NEXCOM will charge for out-of-warranty products in two categories, one is basic diagnostic fee and another is component (product) fee.

Repair Service Charges for Out-of-Warranty Products

NEXCOM will charge for out-of-warranty products in two categories, one is basic diagnostic fee and another is component (product) fee.

System Level

- Component fee: NEXCOM will only charge for main components such as SMD chip, BGA chip, etc. Passive components will be repaired for free, ex: resistor, capacitor.
- Items will be replaced with NEXCOM products if the original one cannot be repaired. Ex: motherboard, power supply, etc.
- Replace with 3rd party products if needed.
- If RMA goods can not be repaired, NEXCOM will return it to the customer without any charge.

Board Level

- Component fee: NEXCOM will only charge for main components, such as SMD chip, BGA chip, etc. Passive components will be repaired for free, ex: resistors, capacitors.
- If RMA goods can not be repaired, NEXCOM will return it to the customer without any charge.

Warnings

Read and adhere to all warnings, cautions, and notices in this guide and the documentation supplied with the chassis, power supply, and accessory modules. If the instructions for the chassis and power supply are inconsistent with these instructions or the instructions for accessory modules, contact the supplier to find out how you can ensure that your computer meets safety and regulatory requirements.

Cautions

Electrostatic discharge (ESD) can damage system components. Do the described procedures only at an ESD workstation. If no such station is available, you can provide some ESD protection by wearing an antistatic wrist strap and attaching it to a metal part of the computer chassis.

Safety Information

Before installing and using the device, note the following precautions:

- Read all instructions carefully.
- Do not place the unit on an unstable surface, cart, or stand.
- Follow all warnings and cautions in this manual.
- When replacing parts, ensure that your service technician uses parts specified by the manufacturer.
- Avoid using the system near water, in direct sunlight, or near a heating device.
- The load of the system unit does not solely rely for support from the rackmounts located on the sides. Firm support from the bottom is highly necessary in order to provide balance stability.
- The computer is provided with a battery-powered real-time clock circuit. There is a danger of explosion if battery is incorrectly replaced. Replace only with the same or equivalent type recommended by the manufacturer. Discard used batteries according to the manufacturer's instructions.

Installation Recommendations

Ensure you have a stable, clean working environment. Dust and dirt can get into components and cause a malfunction. Use containers to keep small components separated.

Adequate lighting and proper tools can prevent you from accidentally damaging the internal components. Most of the procedures that follow require only a few simple tools, including the following:

- A Philips screwdriver
- A flat-tipped screwdriver
- A grounding strap
- An anti-static pad

Using your fingers can disconnect most of the connections. It is recommended that you do not use needle-nose pliers to disconnect connections as these can damage the soft metal or plastic parts of the connectors.

Safety Precautions

1. Read these safety instructions carefully.
2. Keep this User Manual for later reference.
3. Disconnect this equipment from any AC outlet before cleaning. Use a damp cloth. Do not use liquid or spray detergents for cleaning.
4. For plug-in equipment, the power outlet socket must be located near the equipment and must be easily accessible.
5. Keep this equipment away from humidity.
6. Put this equipment on a stable surface during installation. Dropping it or letting it fall may cause damage.
7. The openings on the enclosure are for air convection to protect the equipment from overheating. **DO NOT COVER THE OPENINGS.**
8. Make sure the voltage of the power source is correct before connecting the equipment to the power outlet.
9. Place the power cord in a way so that people will not step on it. Do not place anything on top of the power cord. Use a power cord that has been approved for use with the product and that it matches the voltage and current marked on the product's electrical range label. The voltage and current rating of the cord must be greater than the voltage and current rating marked on the product.
10. All cautions and warnings on the equipment should be noted.
11. If the equipment is not used for a long time, disconnect it from the power source to avoid damage by transient overvoltage.
12. Never pour any liquid into an opening. This may cause fire or electrical shock.
13. Never open the equipment. For safety reasons, the equipment should be opened only by qualified service personnel.
14. If one of the following situations arises, get the equipment checked by service personnel:
 - a. The power cord or plug is damaged.
 - b. Liquid has penetrated into the equipment.
 - c. The equipment has been exposed to moisture.
 - d. The equipment does not work well, or you cannot get it to work according to the user's manual.
 - e. The equipment has been dropped and damaged.
 - f. The equipment has obvious signs of breakage.
15. Do not place heavy objects on the equipment.
16. The unit uses a three-wire ground cable which is equipped with a third pin to ground the unit and prevent electric shock. Do not defeat the purpose of this pin. If your outlet does not support this kind of plug, contact your electrician to replace your obsolete outlet.
17. **CAUTION: DANGER OF EXPLOSION IF BATTERY IS INCORRECTLY REPLACED. REPLACE ONLY WITH THE SAME OR EQUIVALENT TYPE RECOMMENDED BY THE MANUFACTURER. DISCARD USED BATTERIES ACCORDING TO THE MANUFACTURER'S INSTRUCTIONS.**

Technical Support and Assistance

1. For the most updated information of NEXCOM products, visit NEXCOM's website at www.nexcom.com.
2. For technical issues that require contacting our technical support team or sales representative, please have the following information ready before calling:
 - Product name and serial number
 - Detailed information of the peripheral devices
 - Detailed information of the installed software (operating system, version, application software, etc.)
 - A complete description of the problem
 - The exact wordings of the error messages

Warning!

1. Handling the unit: carry the unit with both hands and handle it with care.
2. Maintenance: to keep the unit clean, use only approved cleaning products or clean with a dry cloth.
3. CFast: Turn off the unit's power before inserting or removing a CFast storage card.

Conventions Used in this Manual



Warning:

Information about certain situations, which if not observed, can cause personal injury. This will prevent injury to yourself when performing a task.



Caution:

Information to avoid damaging components or losing data.



Note:

Provides additional information to complete a task easily.

Global Service Contact Information

Headquarters

NEXCOM International Co., Ltd.

9F, No. 920, Chung-Cheng Rd.,
ZhongHe District, New Taipei City, 23586,
Taiwan, R.O.C.

Tel: +886-2-8226-7786

Fax: +886-2-8226-7782

www.nexcom.com

Asia

Taiwan

NexAIoT Co., Ltd.

Taipei Office

13F, No.916, Chung-Cheng Rd.,
ZhongHe District,
New Taipei City, 23586, Taiwan, R.O.C.

Tel: +886-2-8226-7796

Fax: +886-2-8226-7926

Email: sales@nexaiot.com.tw

www.nexaiot.com.tw

NexAIoT Co., Ltd.

Taichung Office

16F, No.250, Sec. 2, Chongde Rd.,
Beitun Dist.,

Taichung City 406, R.O.C.

Tel: +886-4-2249-1179

Fax: +886-4-2249-1172

Email: sales@nexaiot.com.tw

www.nexaiot.com.tw

NexCOBOT Taiwan Co., Ltd.

13F, No.916, Chung-Cheng Rd.,
ZhongHe District,
New Taipei City, 23586, Taiwan, R.O.C.

Tel: +886-2-8226-7786

Fax: +886-2-8226-7926

Email: sales@nexcobot.com.tw

www.nexcobot.com.tw

GreenBase Technology Corp.

13F, No.922, Chung-Cheng Rd.,
Zhonghe Dist.,
New Taipei City, 23586, Taiwan, R.O.C.

Tel: +886-2-8226-7786

Fax: +886-2-8226-7900

Email: sales@nexcom.com.tw

www.nexcom.com.tw

China

NEXSEC Incorporated

5F, No.4, No.7 Fengxian Middle Rd.,
(Beike Industrial Park), Haidian District,
Beijing, 100094, China

Tel: +86-10-5704-2680

Fax: +86-10-5704-2681

Email: sales@nexsec.cn

www.nexsec.cn

NEXCOM Shanghai

No.4, 16 Building,
Shanghai OMNI Tech & Science Park
No. 1699, Douhui Rd.,
Shanghai, 201108, China
Tel: +86-21-5278-5868
Fax: +86-21-3251-6358
Email: sales@nexcom.cn
www.nexcom.cn

NEXCOM Surveillance Technology Corp.

5F, Building C, ZhenHan Industrial Zone,
GanKeng Community, Buji Street,
LongGang District,
ShenZhen, 518112, China
Tel: +86-755-8364-7768
Fax: +86-755-8364-7738
Email: steveyang@nexcom.com.tw
www.nexcom.cn

NEXCOM United System Service

Room 603/604, Huiyinmingzun Plaza Bldg. 1,
No. 609, Yunlin East Rd.,
Shanghai, 200062, China
Tel: +86-21-5278-5868
Fax: +86-21-3251-6358
Email: renwang@nexcom.com.tw
www.nexcom.cn

NEXGOL

1F, Building B4, Electronic 2nd Area,
(Phoenix Lake Industrial Park), Yongchuan Dist.,
Chongqing City, 402160, China
Tel: +86-23-4960-9080
Fax: +86-23-4966-5855
Email: sales@nexcobot.com
www.nexgol.com/NexGoL

Beijing NexGemo Technology Co.,Ltd.

5F, Gemotech Building, No.1, Development Rd.,
Changping International Information Industry Base,
Changping District,
Beijing, 102206, China
Tel: +86-10-8190-9328
Fax: +86-10-8190-9456

Japan**NEXCOM Japan**

9F, Tamachi Hara Bldg.,
4-11-5, Shiba Minato-ku,
Tokyo, 108-0014, Japan
Tel: +81-3-5419-7830
Fax: +81-3-5419-7832
Email: sales@nexcom-jp.com
www.nexcom-jp.com

Europe**United Kingdom
NEXCOM EUROPE**

10 Vincent Avenue,
Crownhill Business Centre,
Milton Keynes, Buckinghamshire
MK8 0AB, United Kingdom
Tel: +44-1908-267121
Fax: +44-1908-262042
Email: sales.uk@nexcom.eu
www.nexcom.eu

**America
USA****NEXCOM USA**

46665 Fremont Blvd.,
Fremont CA 94538, USA
Tel: +1-510-656-2248
Fax: +1-510-656-2158
Email: sales@nexcom.com
www.nexcomusa.com

Package Contents

Before continuing, verify that the ISA 140 package that you received is complete. Your package should have all the items listed in the following table.

Item	Item Number	Name	Qty
1	T601-0000015806	(N)EPE For ISA140 Ver:A Both Squerity 230x170x102mm	1
2	T601-0000015807	(N) Outside Carton For ISA140 Ver:A Both Squerity 380x380x158mm AB FLUTE 16KG (Outside Dimension)	1

Ordering Information

The following below provides ordering information for ISA 140.

Barebone

ISA 140 (P/N: 10L10014000X0)

Intel Atom® x6212RE (Elkhart Lake) processor, with 6 x 1GbE RJ45
with 1 x bypass pair

CHAPTER 1: PRODUCT INTRODUCTION

Overview



Key Features

- Intel Atom® x6212RE (Elkhart Lake) industrial grade processor
- 1 x DDR4 SODIMM slot and support up to 16GB 2400/2667/3200 MT/s
- Storage eMMC up to 8GB for OS
- Storage M.2 Key B slot, supports 2242 for data storage
- 6 x 1GbE RJ45 with 1 x bypass pair
- 1 x M.2 3042 Key B with USB signal
- 1 x Micro SIM slot
- 1 x Minicard full size with PCIe & USB signal
- Supports OOB

Hardware Specifications

Main Board

- Intel Atom® x6212RE (Elkhart Lake) industrial grade processor
- TPM 2.0 onboard

Main Memory

- 1 x DDR4 SODIMM slot support 2400/2667/3200 MT/s up to 16GB

Storage

- Storage eMMC up to 8GB for OS
- Storage M.2 Key B slot, support 2242 for data storage

Interface External

- 6 x 1GbE RJ45 with 1 bypass pair
 - 1 port with OOB support
- 1 x Micro SIM slot
- LED indicator for bypass/LTE/Wi-Fi/SYS/SSD/PWR
- 1 x HDMI
- 1 x Power button
- 1 x Reset button
- 1 x RJ45 for console
- Dual terminal block
- 4 x SMA antenna holes
- 2 x USB 3.0

Interface Internal

- 1 x DDR4 SODIMM slot
- 1 x M.2 2242 Key B slot

- 1 x M.2 3042 Key B slot
- 1 x Minicard full size slot

Power Input

- Dual DC (9~36VDC)

Dimension and Weight

- System size: 165 x 61.7 x 129.25 mm
- Packaging size: 305 x 245 x 195 mm
- Weight without packaging: 1.3kg
- Weight with packaging: 2.19kg

Environment

- Operating temperature: -30°C~70°C:
 - Up to 70°C without M.2 SSD and wireless modules
 - Up to 60°C with M.2 SSD and wireless modules
- Storage temperature: -40°C~85°C
- Relative Humidity: 5%~95% non-condensing

Certifications

- CE/FCC Class A

Knowing Your ISA 140

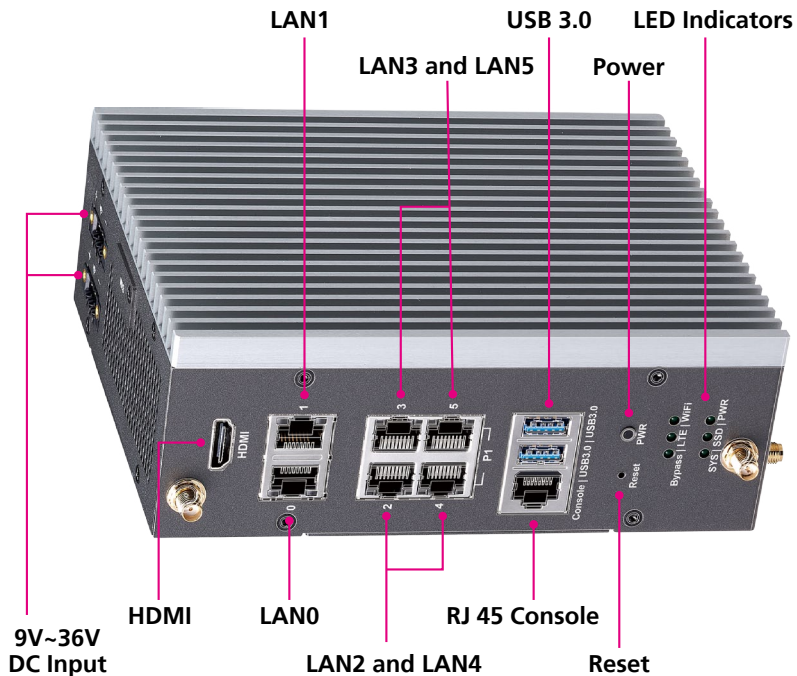

LED Indicators

Indicates the M.2 LTE, M.2 SATA, mini PCIe Wi-Fi, LAN bypass, GPIO and power status of the system.

Power Button

Press to power-on or power-off the system.

Reset Button

Press to reset the system.

USB 3.0 Port

Used to connect USB 3.0/2.0 devices.

RJ45 Console Port

Used to connect to devices with RJ45 type console connection.

LAN 0 to LAN 5 Ports

Used to connect network devices.

HDMI

Used to connect a high-definition display.

9V to 36V DC Power Inputs

Used to plug a DC power cord.

Mechanical Dimensions

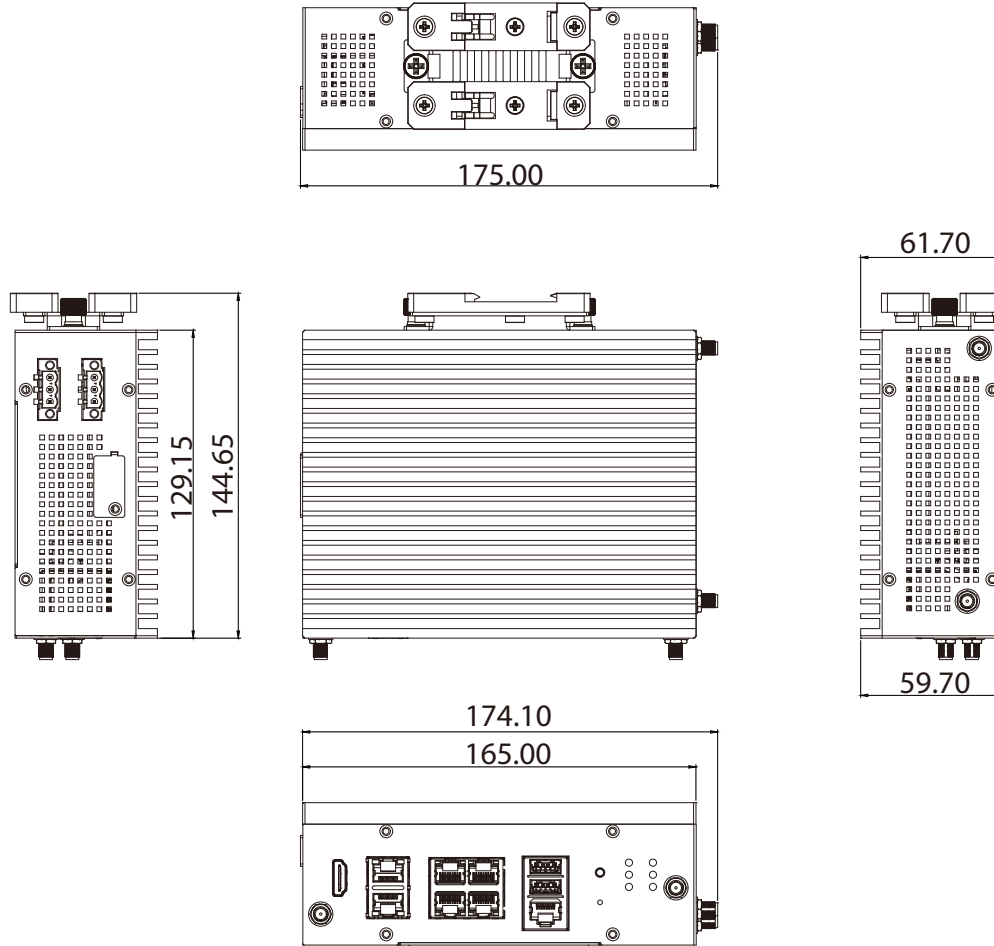

CHAPTER 2: JUMPERS AND CONNECTORS

This chapter describes how to set the jumpers and connectors on the ISA 140 motherboard.

Before You Begin

- Ensure you have a stable, clean working environment. Dust and dirt can get into components and cause a malfunction. Use containers to keep small components separated.
- Adequate lighting and proper tools can prevent you from accidentally damaging the internal components. Most of the procedures that follow require only a few simple tools, including the following:
 - A Philips screwdriver
 - A flat-tipped screwdriver
 - A set of jewelers screwdrivers
 - A grounding strap
 - An anti-static pad
- Using your fingers can disconnect most of the connections. It is recommended that you do not use needle-nosed pliers to disconnect connections as these can damage the soft metal or plastic parts of the connectors.
- Before working on internal components, make sure that the power is off. Ground yourself before touching any internal components, by touching a metal object. Static electricity can damage many of the electronic components. Humid environments tend to have less static electricity than

dry environments. A grounding strap is warranted whenever danger of static electricity exists.

Precautions

Computer components and electronic circuit boards can be damaged by discharges of static electricity. Working on computers that are still connected to a power supply can be extremely dangerous.

Follow the guidelines below to avoid damage to your computer or yourself:

- Always disconnect the unit from the power outlet whenever you are working inside the case.
- If possible, wear a grounded wrist strap when you are working inside the computer case. Alternatively, discharge any static electricity by touching the bare metal chassis of the unit case, or the bare metal body of any other grounded appliance.
- Hold electronic circuit boards by the edges only. Do not touch the components on the board unless it is necessary to do so. Don't flex or stress the circuit board.
- Leave all components inside the static-proof packaging that they shipped with until they are ready for installation.
- Use correct screws and do not over tighten screws.

Jumper Settings

A jumper is the simplest kind of electric switch. It consists of two metal pins and a cap. When setting the jumpers, ensure that the jumper caps are placed on the correct pins. When the jumper cap is placed on both pins, the jumper is short. If you remove the jumper cap, or place the jumper cap on just one pin, the jumper is open.

Refer to the illustrations below for examples of what the 2-pin and 3-pin jumpers look like when they are short (on) and open (off).

Two-Pin Jumpers: Open (Left) and Short (Right)

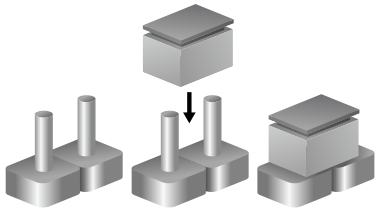

Three-Pin Jumpers: Pins 1 and 2 are Short

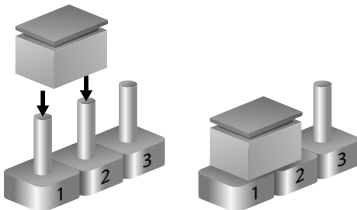

Locations of the Jumpers and Connectors

The figure below is the top view of the main board used in the system. It shows the location of the jumpers and connectors.

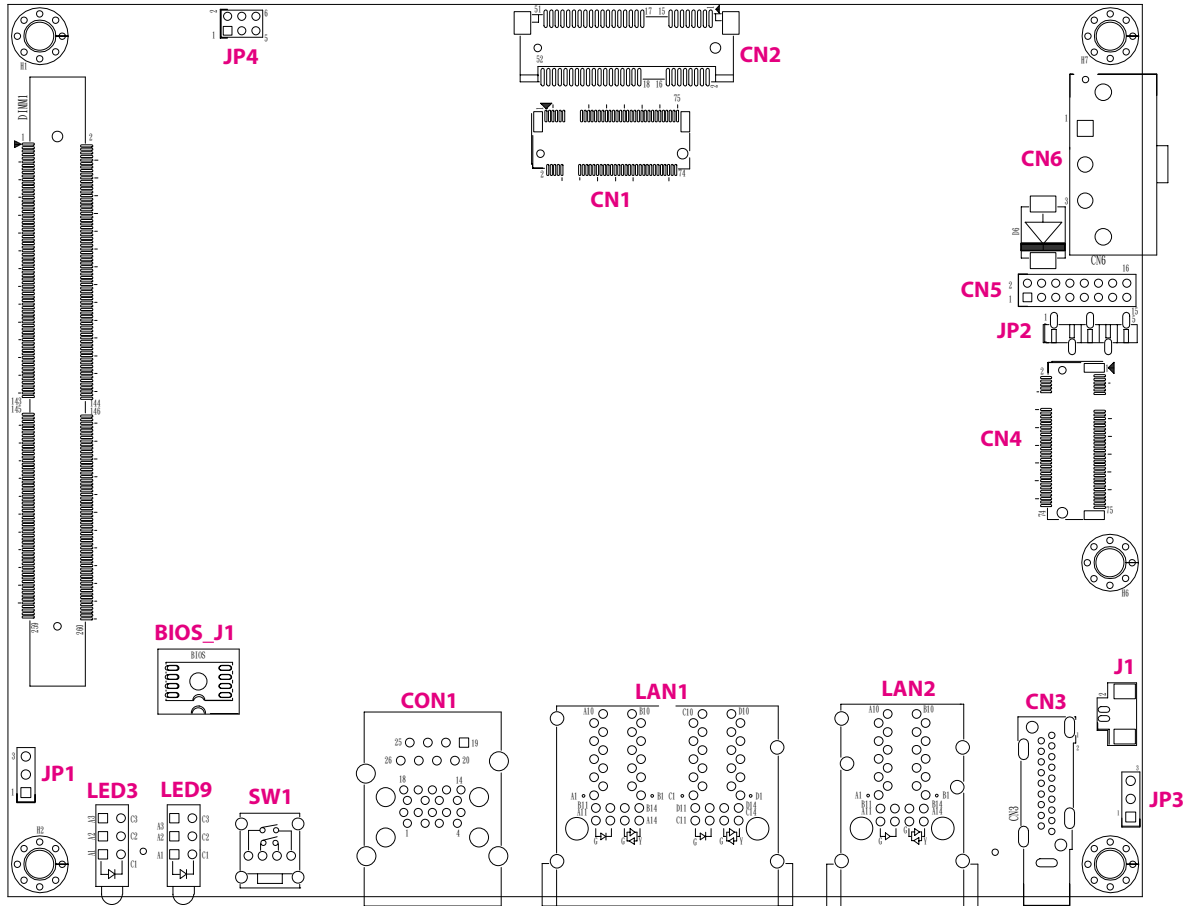

The figure below is the bottom view of the main board used in the system.

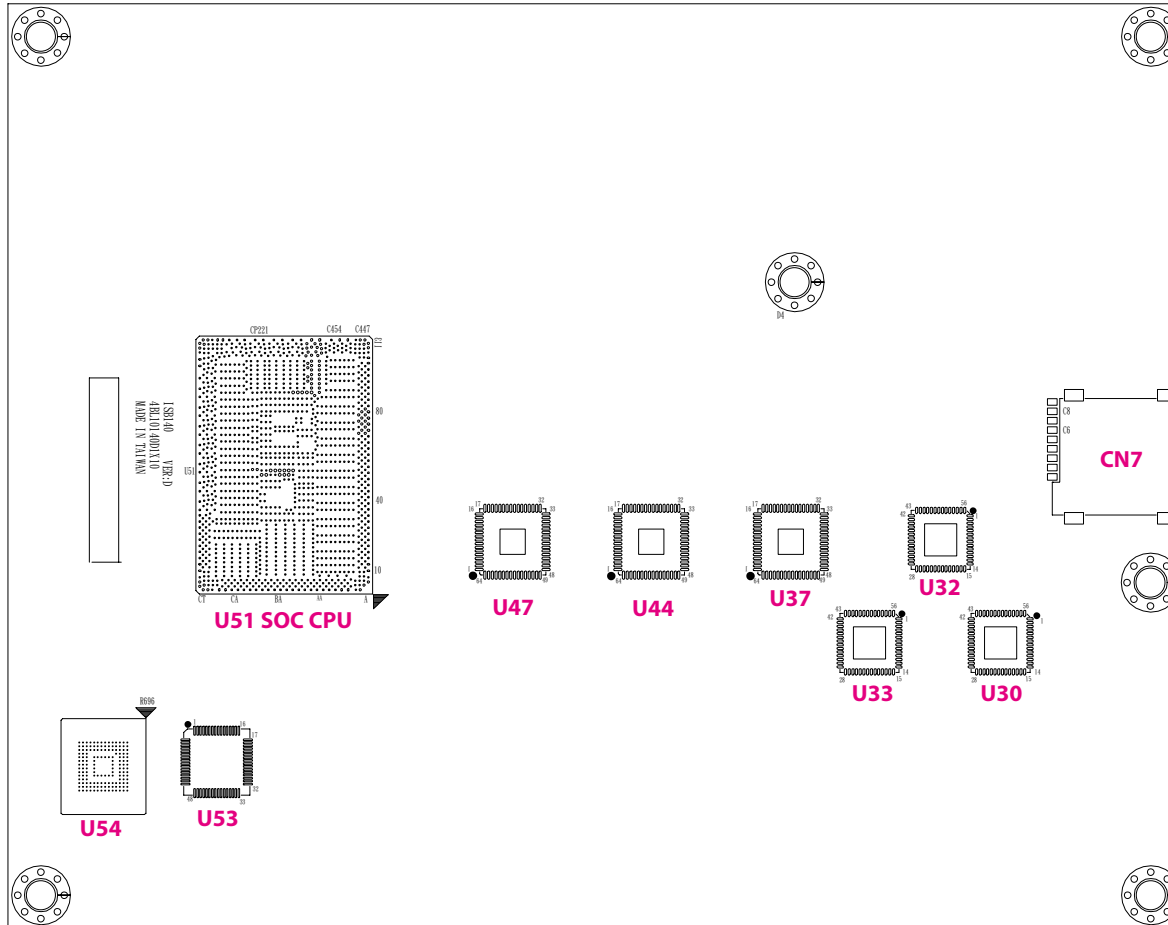

Jumpers

CMOS Clear

Connector type: 1x3 3-pin header, 2.54mm pitch

Connector location: JP1, JP3

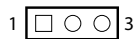

JP1	
Pin	Definition
1	SRTC_RST_N
2	GND
3	NC

JP3	
Pin	Definition
1	NC
2	GND
3	RTC_RST_N

Programmable for MCU

Connector type: 1x5 5-pin header, 2.54mm pitch

Connector location: JP2

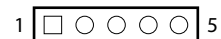

Pin	Definition	Pin	Definition
1	MCU1_NMCLR	2	VDD_MCU
3	GND	4	MCU1_PGED
5	MCU1_PCEC		

Connector Pin Definitions

External I/O Interfaces

USB3.0

Connector location: CON1

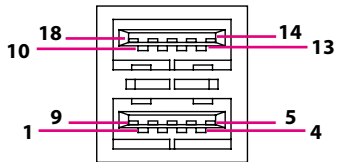

Pin	Definition	Pin	Definition
1	PV5_USB30	2	USB2N0_C
3	USB2P0_C	4	GND
5	USB3RN0_C	6	USB3RP0_C
7	GND	8	USB3TN0_C
9	USB3TP0_C	10	PV5_USB30
11	USB2N1_C	12	USB2P1_C
13	GND	14	USB3RN1_C
15	USB3RP1_C	16	GND
17	USB3TN1_C	18	USB3TP1_C

HDMI Connector

Connector location: CN3

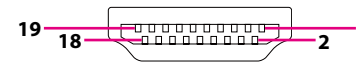

Pin	Definition	Pin	Definition
1	HDMI_DATA2_P_C	2	GND
3	HDMI_DATA2_N_C	4	HDMI_DATA1_P_C
5	GND	6	HDMI_DATA1_N_C
7	HDMI_DATA0_P_C	8	GND
9	HDMI_DATA0_N_C	10	HDMI_CLK_P_C
11	GND	12	HDMI_CLK_N_C
13	NC	14	NC
15	HDMI_CLK	16	HDMI_DAT
17	GND	18	P5V_HDMIC
19	HDMI_HPD_C		

Internal Connectors

M.2 B-Key SATA

Connector location: CN1

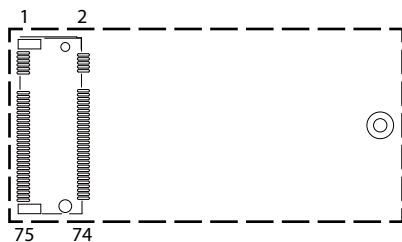

Pin	Definition
41	M2_RX_DP
43	M2_RX_DN
47	M2_TX_DN
49	M2_TX_DP

M.2 B-Key LTE

Connector location: CN4

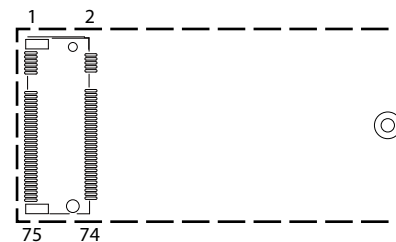

Pin	Definition	Pin	Definition
29	PCIE_LTE_RXN	30	UIM1_RESET
31	PCIE_LTE_RXP	32	UIM1_CLK
35	PCIE_LTE_TXN	34	UIM1_DATA
37	PCIE_LTE_TXP	36	UIM1_PWR

Mini PCIe Slot

Connector location: CN2

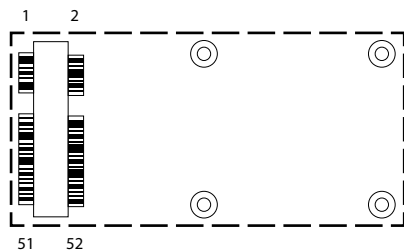

Pin	Definition	Pin	Definition
11	PCIE_CLK3_DN	13	PCIE_CLK3_DP
23	WIFI_RXN	25	WIFI_RXP
31	WIFI_TXN	33	WIFI_TXP
36	USB2_P2_DN	38	USB2_P2_DP

Power and Reset

Connector location: SW1

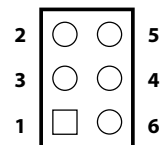

Pin	Definition	Pin	Definition
1	GND	2	GND
3	GND	4	FP_PWRBTN_N_R
5	SYS_RESET_N_R	6	GND

Micro SIM Connector

Connector location: CN7

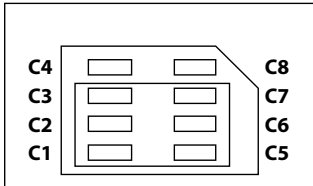

Pin	Definition	Pin	Definition
1	UIM1_VCC	2	UIM1_RESET
3	UIM1_CLK	4	UIM1_D0
5	GND	6	UIM1_VPP
7	UIM1_DATA	8	NC
9	SIM_DET	10	NC

Block Diagram

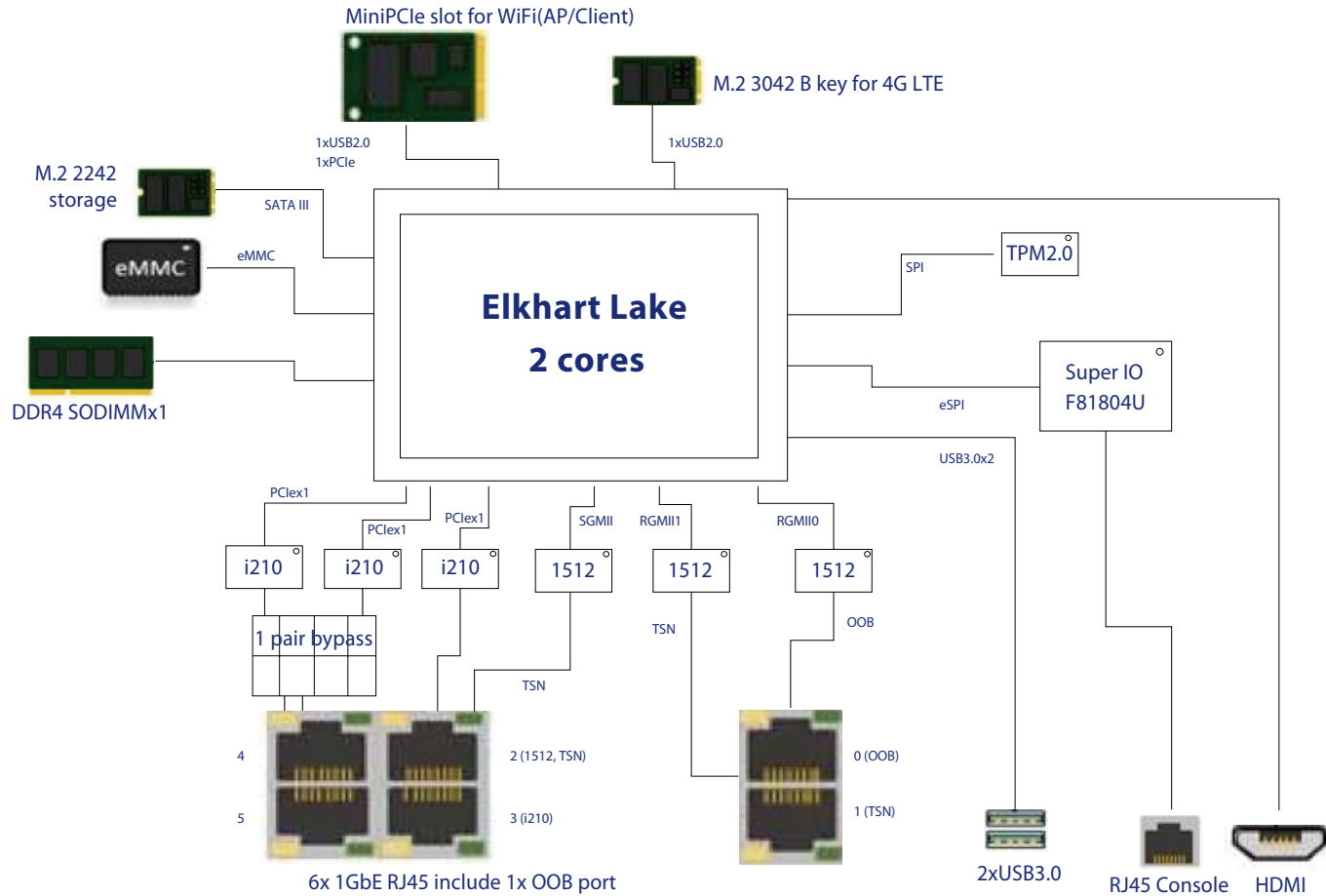

CHAPTER 3: SYSTEM SETUP

Removing the Bottom Chassis Cover



Prior to removing the chassis cover, make sure the unit's power is off and disconnected from the power sources to prevent electric shock or system damage.

1. The screws on the bottom cover are used to secure the cover to the chassis. Remove these screws and put them in a safe place for later use.

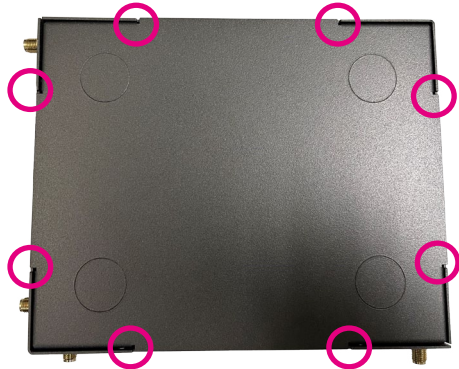

2. With the screws removed, lift up the cover and remove it from the chassis.

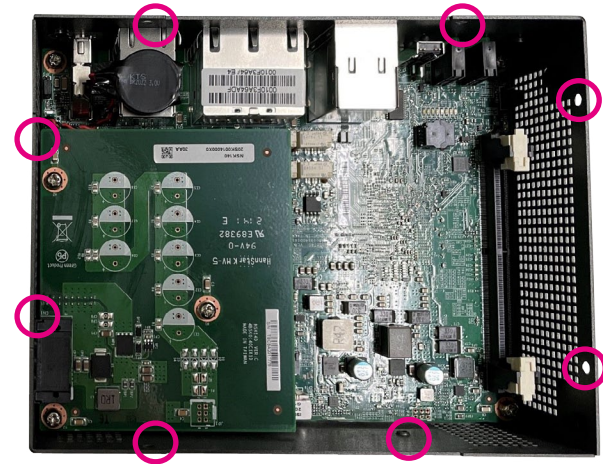

Installing an M.2 SSD Storage Module

To install an M.2 SSD module, please follow the instructions below.

1. Remove the four screws from the side cover, and the three screws from the board.

2. Remove the power panel.

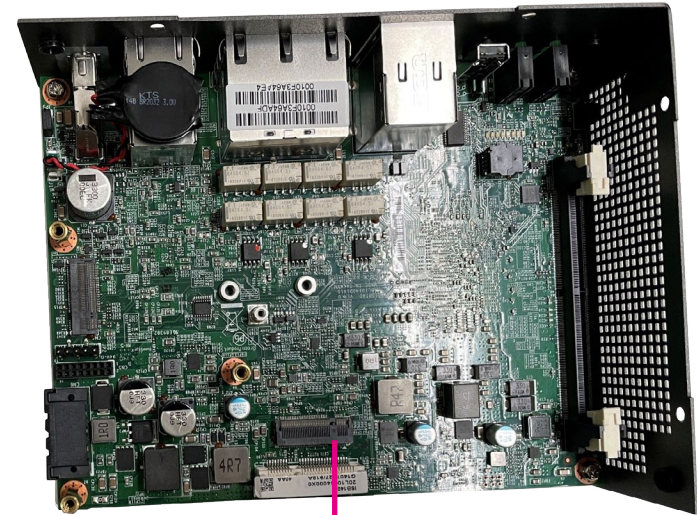
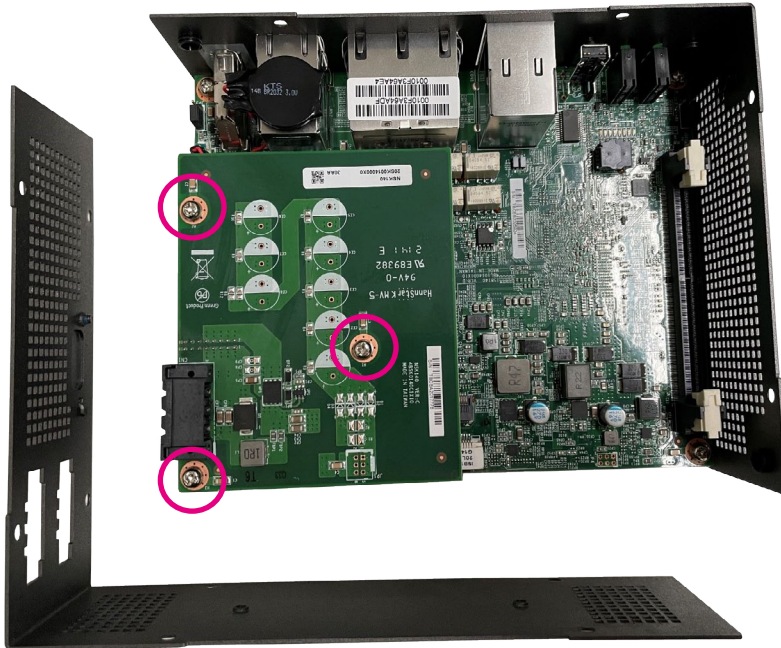

M.2 SSD slot

3. Insert the M.2 SSD module into the M.2 slot at a 45 degree angle until the gold-plated connector on the edge of the module completely disappears inside the slot.
4. With the module fully inserted, tighten a screw into the mounting hole on the module to secure it.

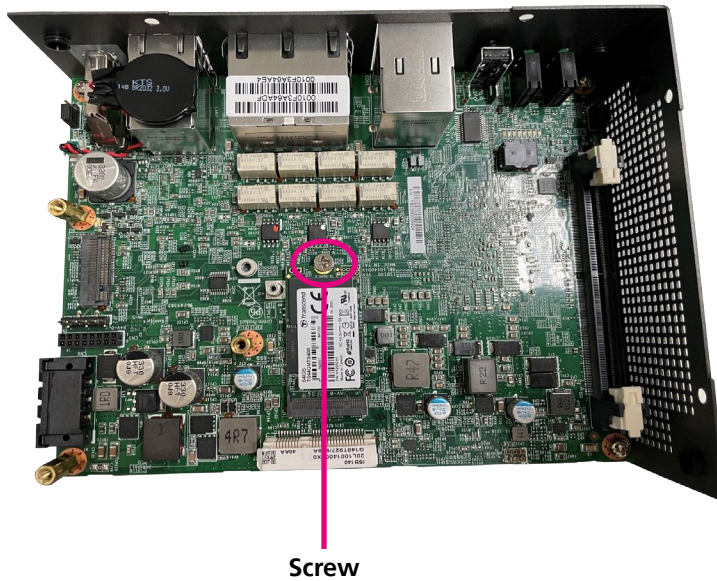

Installing SO-DIMM Memory Modules

1. With the chassis cover removed, install a memory module in the SO-DIMM socket. Push the module down until the clips on both sides of the socket lock into position. The gold-plated connector on the edge of the module will almost completely disappear inside the socket.

2. Push the module down until the clips on both sides of the socket lock into position. You will hear a distinctive “click” sound, indicating the module is correctly locked into position.

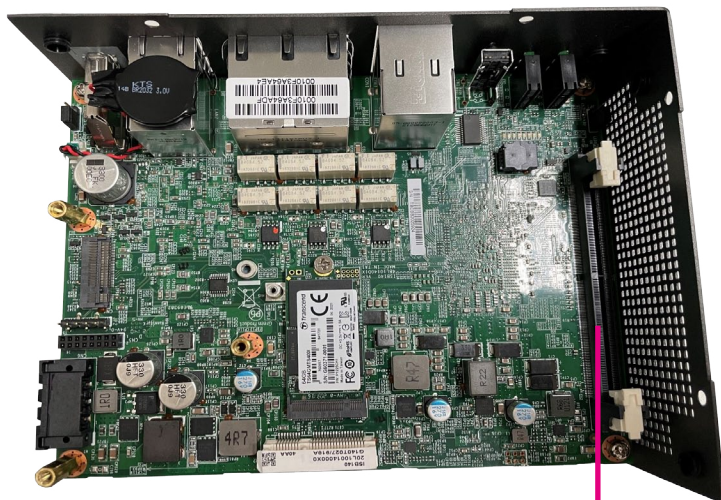

SO-DIMM

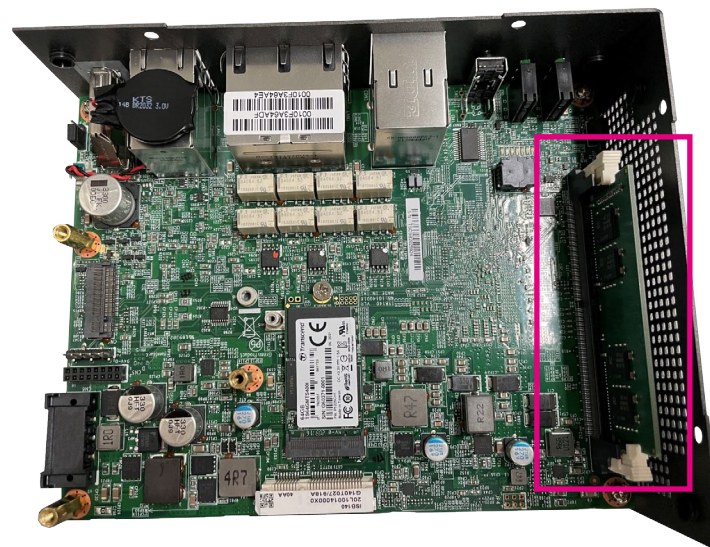

Installing a Wireless LAN Module



The system is equipped with a mini-PCIe slot for wireless LAN module. To install the module, please follow the instructions below.

1. With the bottom cover removed, locate the mini-PCIe slot on the mainboard.

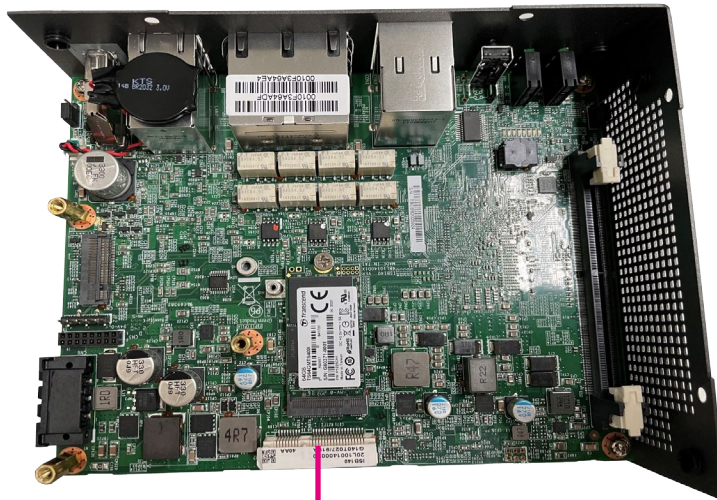

mini-PCIe slot

2. Insert the Wi-Fi module into the slot at a 45 degree angle until the goldplated connector on the edge of the module completely disappears inside the slot. Tighten a screw into the mounting hole on the module to secure it.



3. Attach the RF cables onto the module and mount the other ends of the cables to the antenna holes on the chassis.

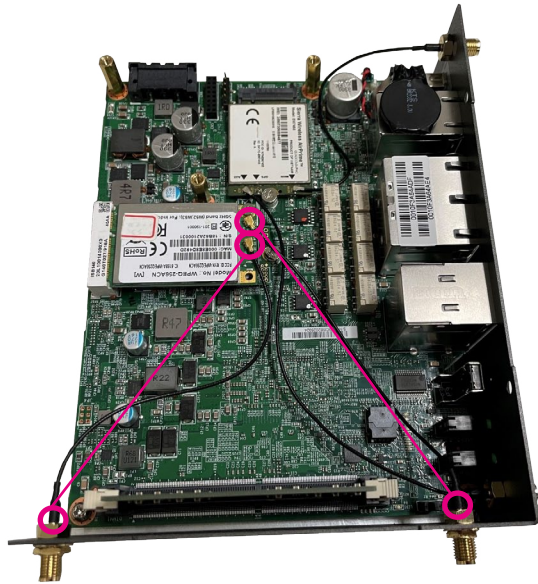

4. Insert the 2 rings (ring 1 then ring 2) into the Wi-Fi antenna jacks. Please remove the two antenna hole covers on the front panel before installing the antenna jacks.



Installing a LTE Module



Please note that a Wi-Fi module cannot be installed after installing a LTE module. Only one can be installed at a time.

1. With the bottom cover removed, locate the mini-PCIe slot on the mainboard.

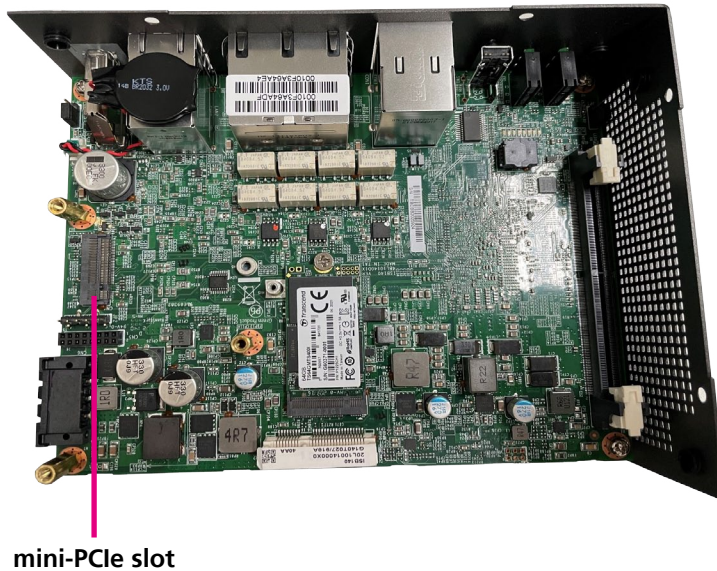

2. Insert the Wi-Fi module into the slot at a 45 degree angle until the goldplated connector on the edge of the module completely disappears inside the slot. Push the module down and fasten screws into the mounting holes to secure the module.



3. Attach the RF cables onto the module and mount the other ends of the cables to the antenna holes on the chassis.

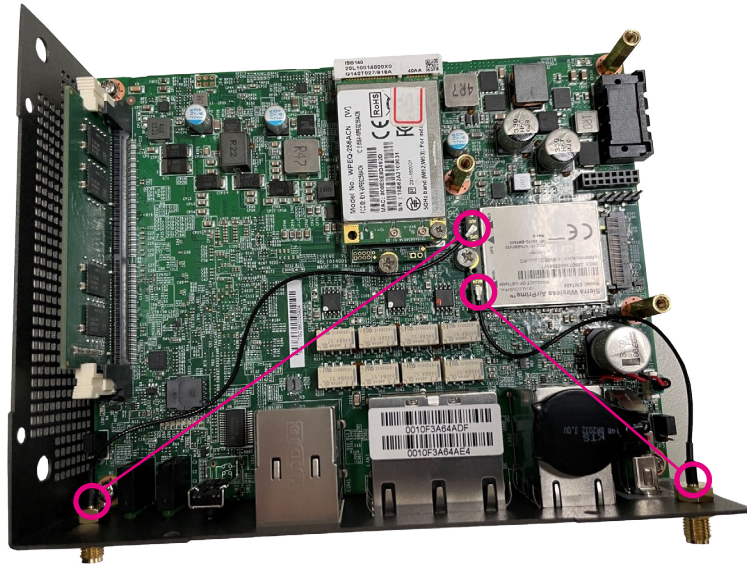

4. Insert the 2 rings (ring 1 then ring 2) into the LTE antenna jacks. Please remove the two antenna hole covers on the front panel before installing the antenna jacks.

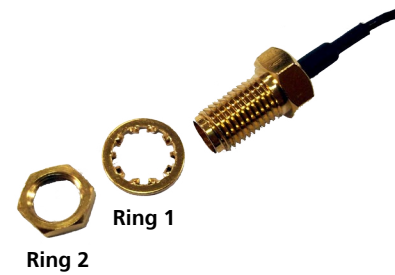

Installing a SIM Card

1. The SIM card socket is located on the right side of the system.

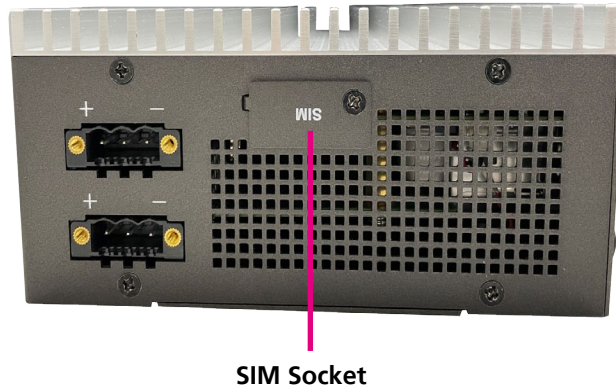

2. Remove the mounting screws on the cover of the SIM card socket then remove the cover. Insert the SIM card and secure the SIM card cover after installation.

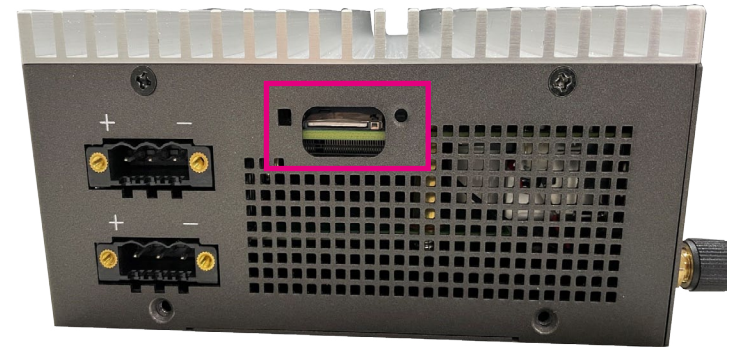

CHAPTER 4: BIOS SETUP

This chapter describes how to use the BIOS setup program for ISA 140. The BIOS screens provided in this chapter are for reference only and may change if the BIOS is updated in the future.

To check for the latest updates and revisions, visit the NEXCOM website at www.nexcom.com.tw.

About BIOS Setup

The BIOS (Basic Input and Output System) Setup program is a menu driven utility that enables you to make changes to the system configuration and tailor your system to suit your individual work needs. It is a ROM-based configuration utility that displays the system's configuration status and provides you with a tool to set system parameters.

These parameters are stored in non-volatile battery-backed-up CMOS RAM that saves this information even when the power is turned off. When the system is turned back on, the system is configured with the values found in CMOS.

With easy-to-use pull down menus, you can configure such items as:

- Hard drives, diskette drives, and peripherals
- Video display type and display options
- Password protection from unauthorized use
- Power management features

The settings made in the setup program affect how the computer performs. It is important, therefore, first to try to understand all the setup options, and second, to make settings appropriate for the way you use the computer.

When to Configure the BIOS

- This program should be executed under the following conditions:
 - When changing the system configuration
 - When a configuration error is detected by the system and you are prompted to make changes to the setup program
 - When resetting the system clock
 - When redefining the communication ports to prevent any conflicts
 - When making changes to the Power Management configuration
 - When changing the password or making other changes to the security setup

Normally, CMOS setup is needed when the system hardware is not consistent with the information contained in the CMOS RAM, whenever the CMOS RAM has lost power, or the system features need to be changed.

Default Configuration

Most of the configuration settings are either predefined according to the Load Optimal Defaults settings which are stored in the BIOS or are automatically detected and configured without requiring any actions. There are a few settings that you may need to change depending on your system configuration.

Entering Setup











When the system is powered on, the BIOS will enter the Power-On Self Test (POST) routines. These routines perform various diagnostic checks; if an error is encountered, the error will be reported in one of two different ways:

- If the error occurs before the display device is initialized, a series of beeps will be transmitted.
- If the error occurs after the display device is initialized, the screen will display the error message.

Powering on the computer and immediately pressing allows you to enter Setup.

Press the  key to enter Setup:

Legends

Key	Function
	Moves the highlight left or right to select a menu.
	Moves the highlight up or down between sub-menus or fields.
	Exits the BIOS Setup Utility.
	Scrolls forward through the values or options of the highlighted field.
	Scrolls backward through the values or options of the highlighted field.
	Selects a field.
	Displays General Help.
	Load previous values.
	Load optimized default values.
	Saves and exits the Setup program.
	Press <Enter> to enter the highlighted sub-menu

Scroll Bar

When a scroll bar appears to the right of the setup screen, it indicates that there are more available fields not shown on the screen. Use the up and down arrow keys to scroll through all the available fields.

Submenu

When “▶” appears on the left of a particular field, it indicates that a submenu which contains additional options are available for that field. To display the submenu, move the highlight to that field and press  .

BIOS Setup Utility

Once you enter the AMI BIOS Setup Utility, the Main Menu will appear on the screen. The main menu allows you to select from several setup functions and one exit. Use arrow keys to select among the items and press  to accept or enter the submenu.

Main

The Main menu is the first screen that you will see when you enter the BIOS Setup Utility.

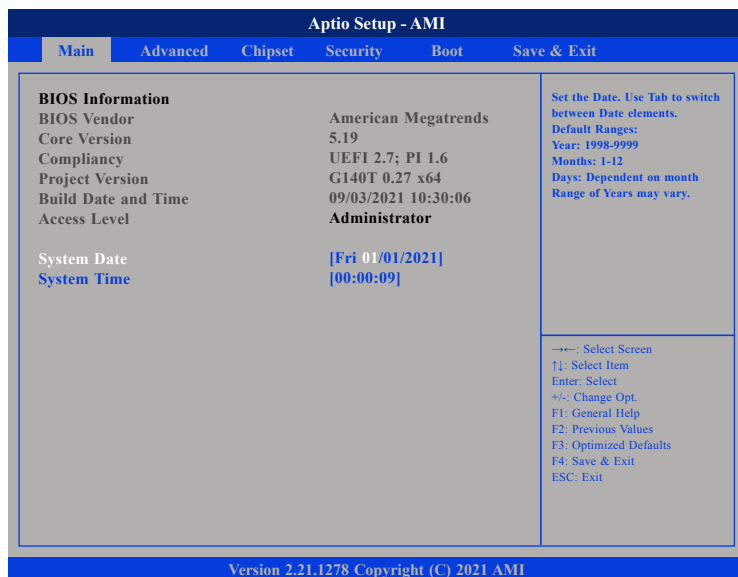

System Date

The date format is <day>, <month>, <date>, <year>. Day displays a day, from Monday to Sunday. Month displays the month, from January to December. Date displays the date, from 1 to 31. Year displays the year, from 1999 to 2099.

System Time

The time format is <hour>, <minute>, <second>. The time is based on the 24-hour military-time clock. For example, 1 p.m. is 13:00:00. Hour displays hours from 00 to 23. Minute displays minutes from 00 to 59. Second displays seconds from 00 to 59.

Advanced

The Advanced menu allows you to configure your system for basic operation. Some entries are defaults required by the system board, while others, if enabled, will improve the performance of your system or let you set some features according to your preference.



Setting incorrect field values may cause the system to malfunction.

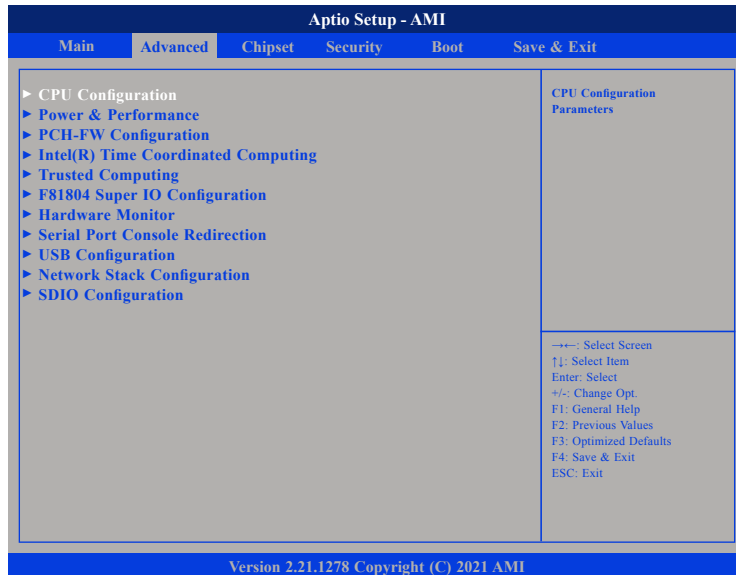

CPU Configuration

This section is used to configure the CPU.

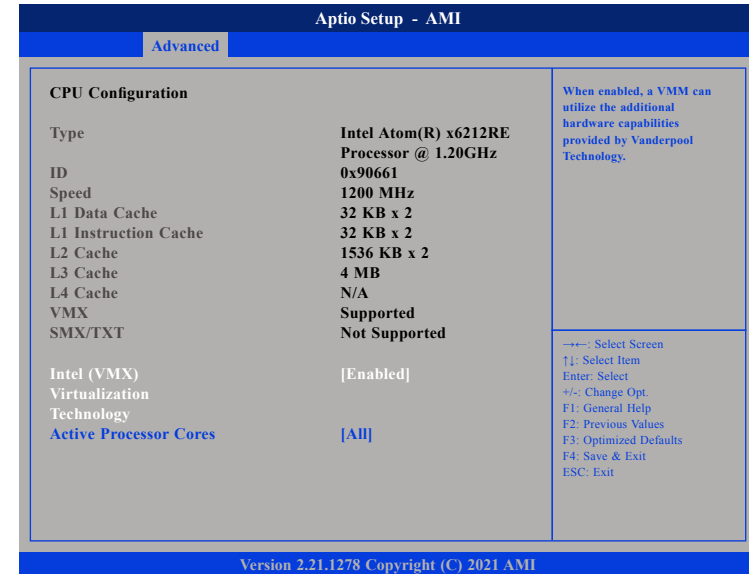

Intel® Virtualization Technology

When this field is set to Enabled, the VMM can utilize the additional hardware capabilities provided by Vanderpool Technology.

Active Processor Cores

Select the number of cores to enable in each processor package.

Power & Performance

This section is used to configure the CPU power management features.

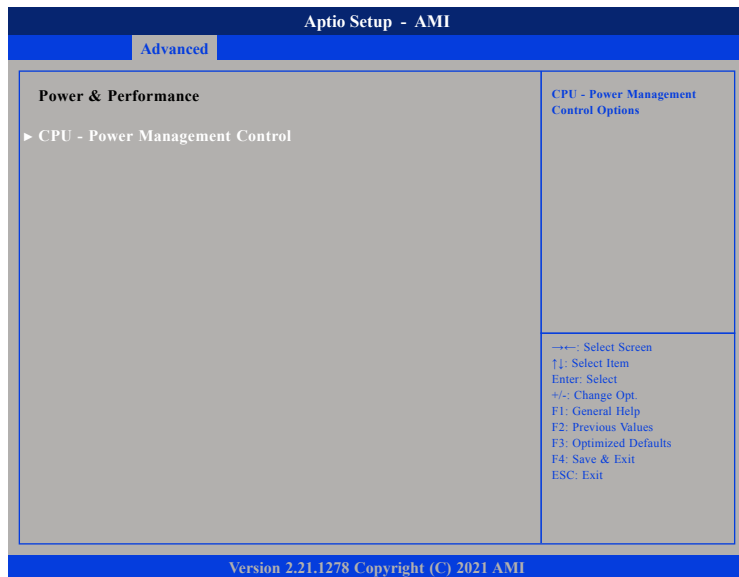

CPU - Power Management Control

Enters the CPU - Power Management Control sub-menu.

CPU - Power Management Control

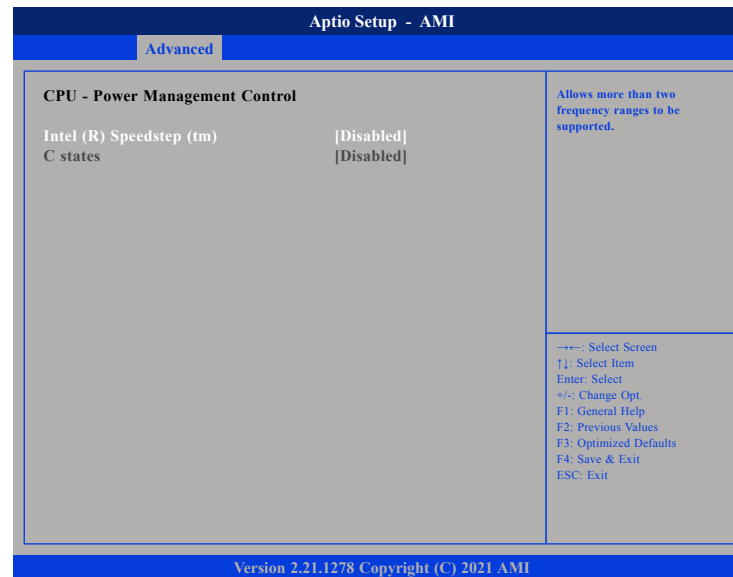

Intel® SpeedStep™

Enables or disables Intel SpeedStep technology.

C states

Enables or disables CPU C states support for power saving.

PCH-FW Configuration

This section is used to configure the firmware update options.

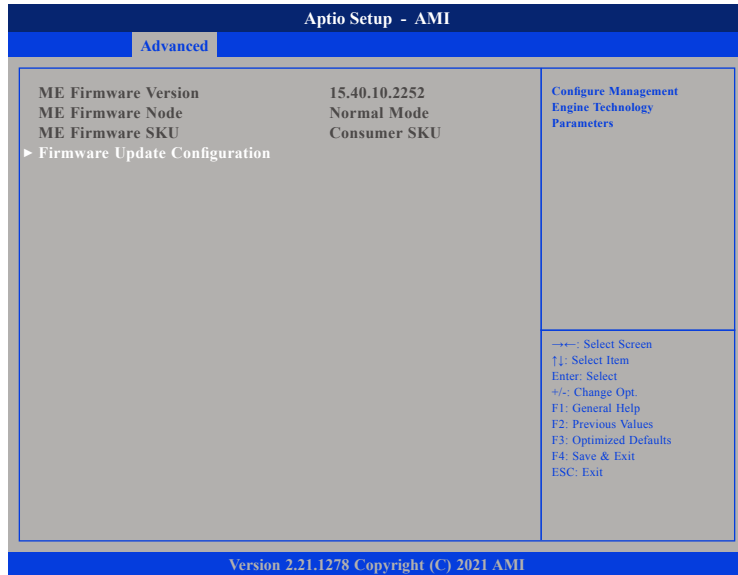

Firmware Update Configuration

Enters the Firmware Update Configuration submenu.

PCH-FW Configuration

This section is used to configure the firmware update options.

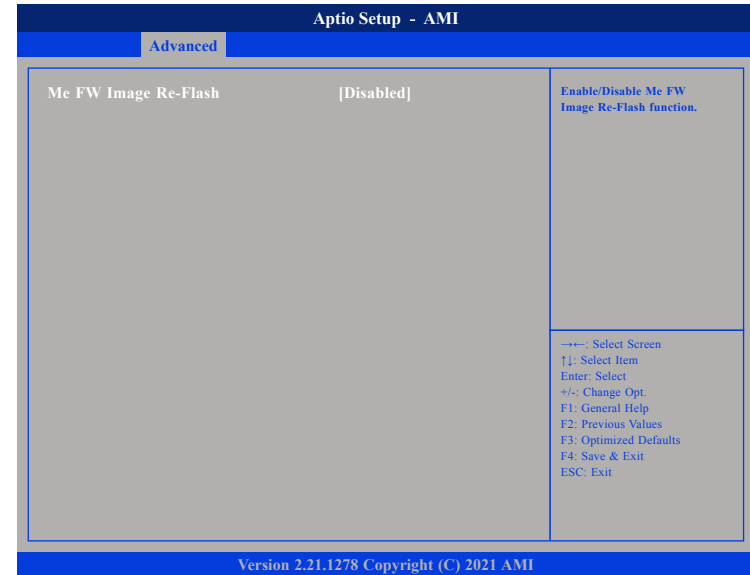

Me FW Image Re-Flash

Enables or disables the ME firmware image re-flash function.

Intel(R) Time Coordinated Computing

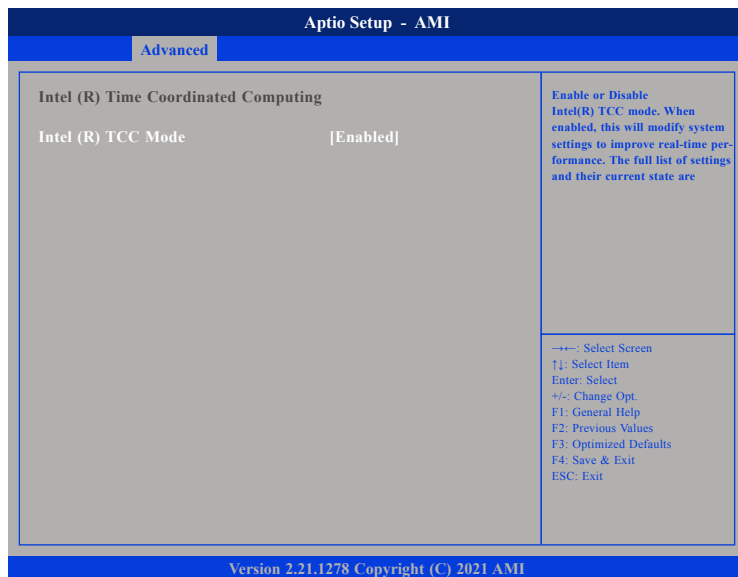

Intel (R) TCC Mode

Enable or disable Intel (R) TCC mode. When enabled, this will modify system settings to improve real-time performance. The full list of settings and their current state are displayed below when Intel(R) TCC mode is enabled.

Trusted Computing

This section is used to configure Trusted Platform Module (TPM) settings.

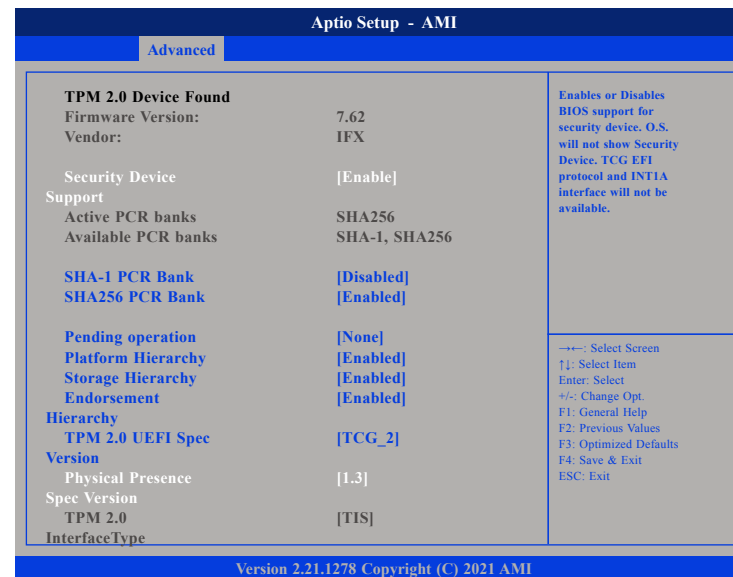

Security Device Support

Enables or disables BIOS support for security device. O.S will not show Security Device. TCG EFI protocol and INT1A interface will not be available.

SHA-1 PCR Bank

Enables or disables SHA-1 PCR Bank.

SHA256 PCR Bank

Enables or disables SHA256 PCR Bank.

Pending operation

Schedules an operation for the security device.

Platform Hierarchy

Enables or disables Platform Hierarchy.

Storage Hierarchy

Enables or disables Storage Hierarchy.

Endorsement Hierarchy

Enables or disables Endorsement Hierarchy.

TPM2.0 UEFI Spec Version

Configures the TPM2.0 UEFI spec version.

TCG_1_2: The compatible mode Windows 8/Windows 10.

TCG_2: Support new TCG2 protocol and event format for Windows 10 or later.

Physical Presence Spec Version

Configures which physical presence spec version the OS will support. Please note that some HCK tests might not support 1.3.

F81804 Super IO Configuration

This section is used to configure the serial ports.

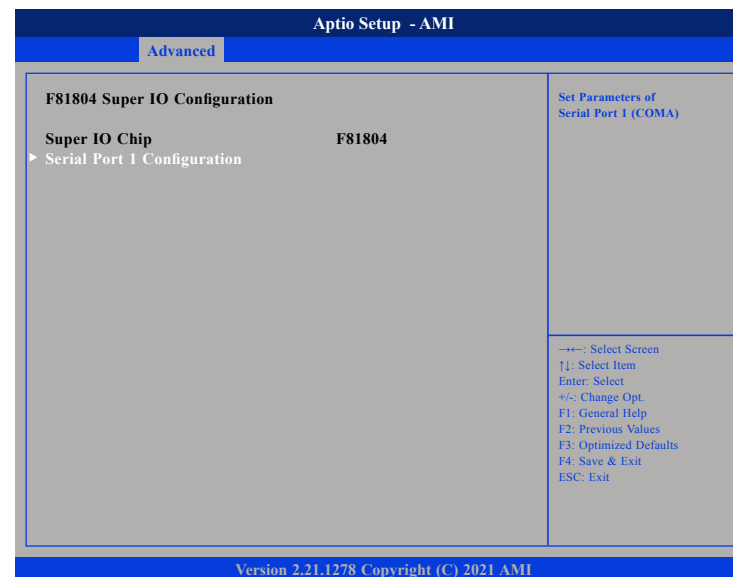

Super IO Chip

Displays the Super I/O chip used on the board.

Serial Port 1 Configuration

This section is used to configure serial port 1.

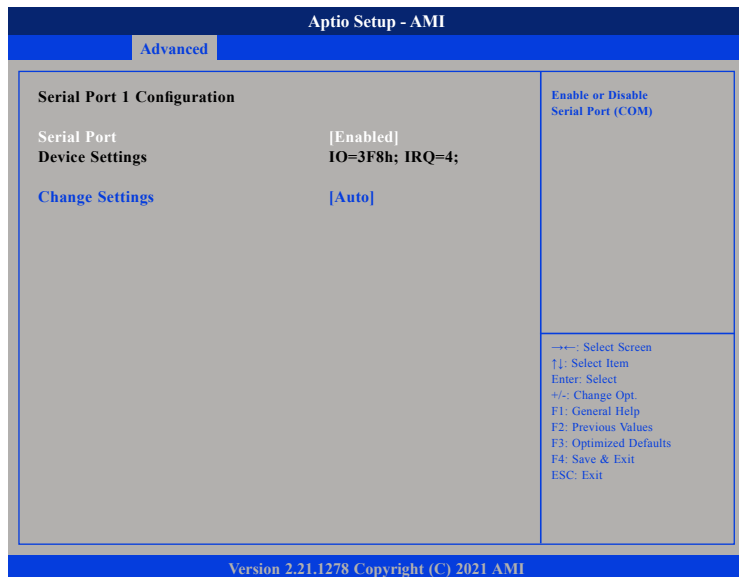

Serial Port

Enables or disables the serial port.

Change Settings

Selects an optimal setting for the Super IO device.

Hardware Monitor

This section is used to monitor hardware status such as temperature, fan speed and voltages.

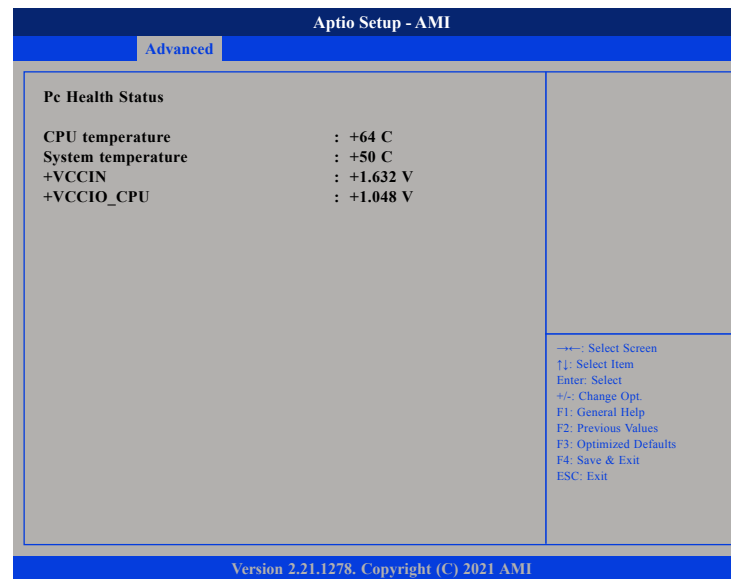

CPU temperature

Detects and displays the current CPU temperature.

System temperature

Detects and displays the current system temperature.

+VCCIN to +VCCIO_CPU

Detects and displays the +VCCIN and +VCCIO_CPU voltage.

Serial Port Console Redirection

This section is used to configure the serial port that will be used for console redirection.

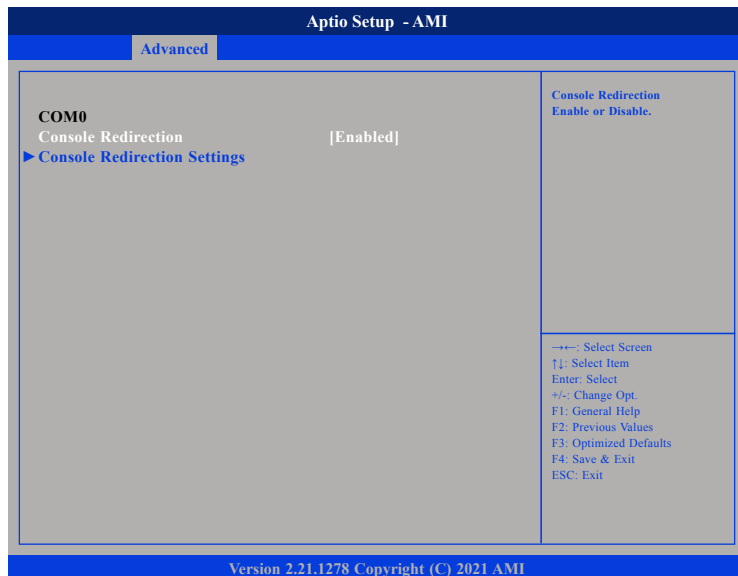

Console Redirection

Enables or disables the console redirection.

COM0 Console Redirection Settings

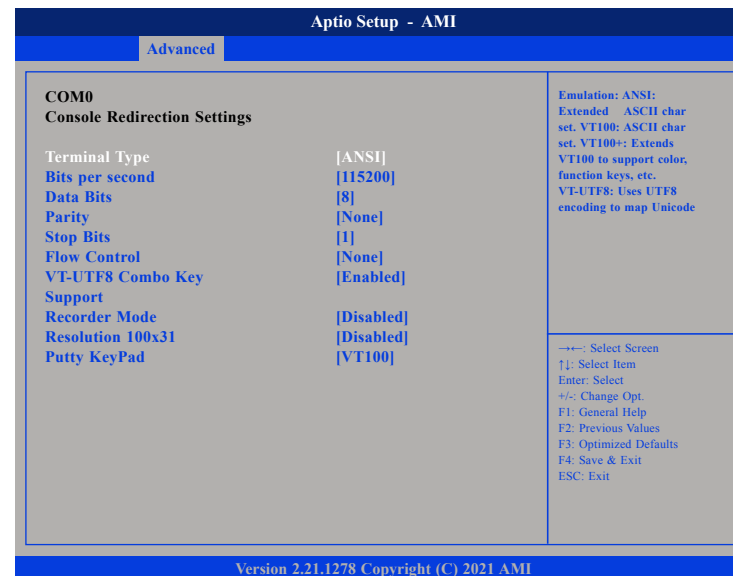

Terminal Type

ANSI Extended ASCII character set.

VT100 ASCII character set.

VT100+ Extends VT100 to support color, function keys, etc.

VT-UTF8 Uses UTF8 encoding to map Unicode characters onto 1 or more bytes.

Bits Per Second

Selects the serial port transmission speed. The speed must match the other side. Long or noisy lines may require a lower speed.

Data Bits

The options are 7 and 8.

Parity

A parity bit can be sent with the data bits to detect some transmission errors.

Even Parity bit is 0 if the number of 1's in the data bits is even.

Odd Parity bit is 0 if number of 1's in the data bits is odd.

Stop Bits

Stop bits indicate the end of a serial data packet. (A start bit indicates the beginning). The standard setting is 1 stop bit. Communication with slow devices may require more than 1 stop bit.

Flow Control

Flow control can prevent data loss from buffer overflow. When sending data and the receiving buffers are full, a "stop" signal can be sent to stop the data flow.

VT-UTF8 Combo Key Support

Enables or disables VT-UTF8 combo key support.

Recorder Mode

When this field is enabled, only text will be sent. This is to capture the terminal data.

Resolution 100x31

Enables or disables extended terminal resolution.

Putty Keypad

Selects the Putty keyboard emulation type.

USB Configuration

This section is used to configure the USB.

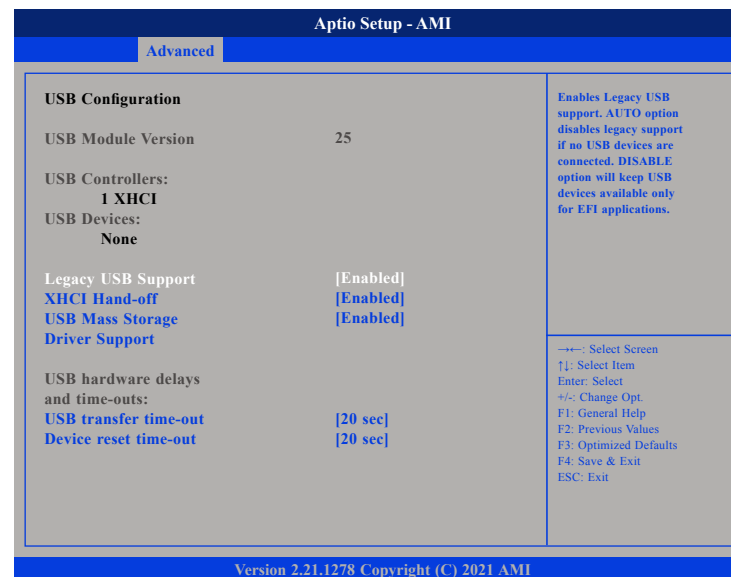

Legacy USB Support

Enable Enables Legacy USB.

Auto Disables support for Legacy when no USB devices are connected.

Disable Keeps USB devices available only for EFI applications.

XHCI Hand-off

This is a workaround for OSs that does not support XHCI hand-off. The XHCI ownership change should be claimed by the XHCI driver.

USB Mass Storage Driver Support

Enables or disables USB mass storage device driver support.

USB Transfer Time-out

The time-out value for control, bulk, and Interrupt transfers.

Device Reset Time-out

Selects the USB mass storage device's start unit command timeout.

Network Stack

This section is used to configure the network stack.

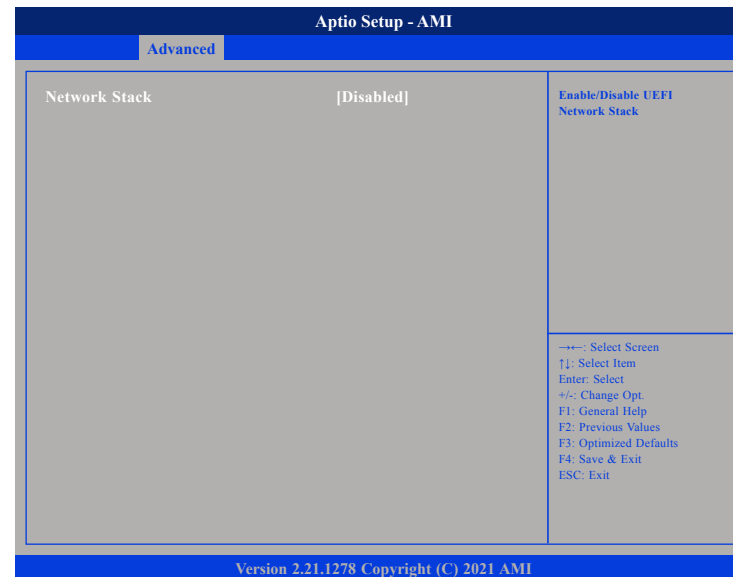

Network Stack

Enables or disables UEFI network stack.

SDIO Configuration

This section is used to configure the SDIO access mode.

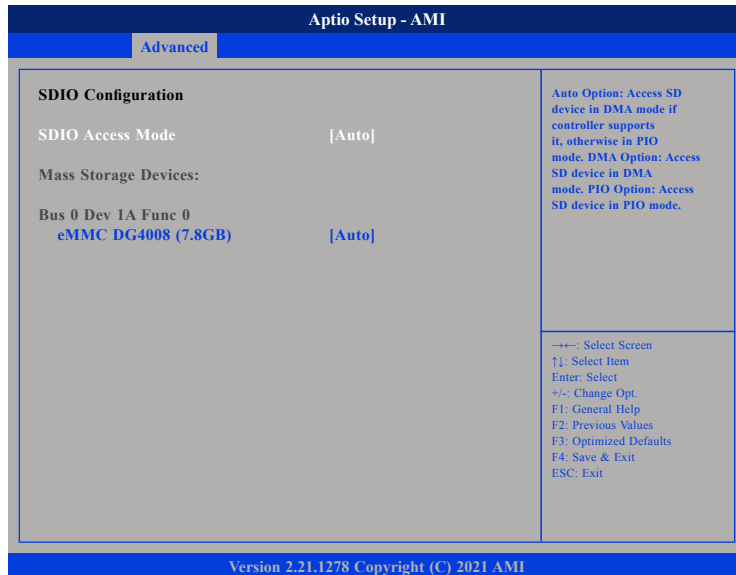

SDIO Configuration

Auto Option Access SD device in DMA mode if controller support it, otherwise in PIO mode.

DAM Option Access SD device in DMA mode.

PIO Option Access SD device in PIO mode.

Chipset

This section gives you functions to configure the system based on the specific features of the chipset. The chipset manages bus speeds and access to system memory resources.

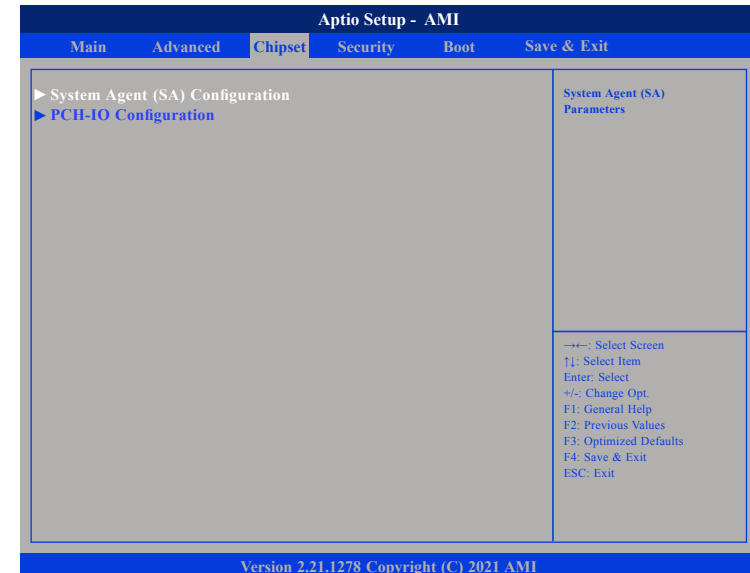

System Agent (SA) Configuration

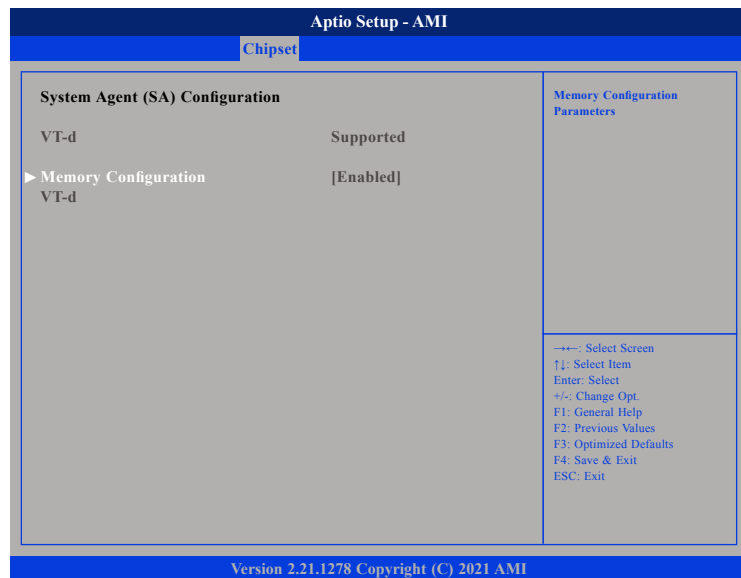

VT-d

Enables or disables the VT-d.

Memory Configuration

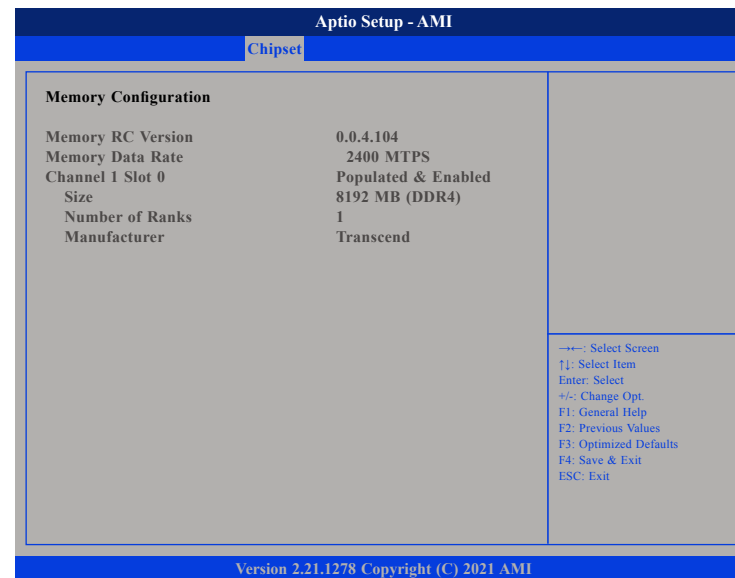

PCH-IO Configuration

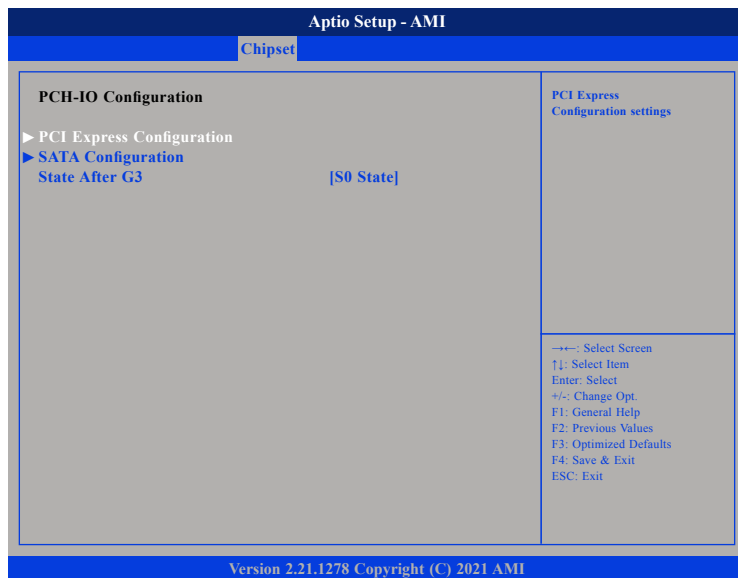

High Precision Timer

Enables or disables high precision event timer.

Restore AC Power Loss

Select the AC power state when power is re-applied after a power failure.

PCI Express Configuration

This section is used to configure PCI Express configuration.

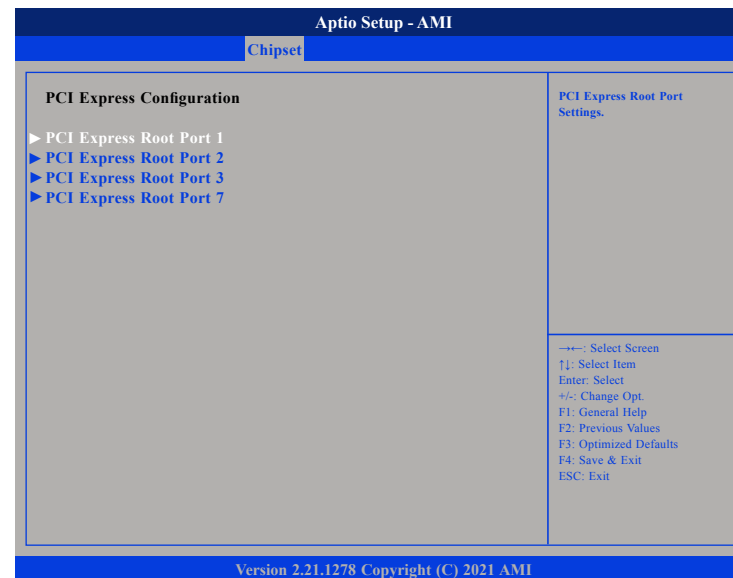

PCI Express Root Port 1, 2, 3, 7

Settings for PCI Express root port 1, 2, 3 and 7.

PCI Express Configuration

This section is used to configure PCI Express configuration.

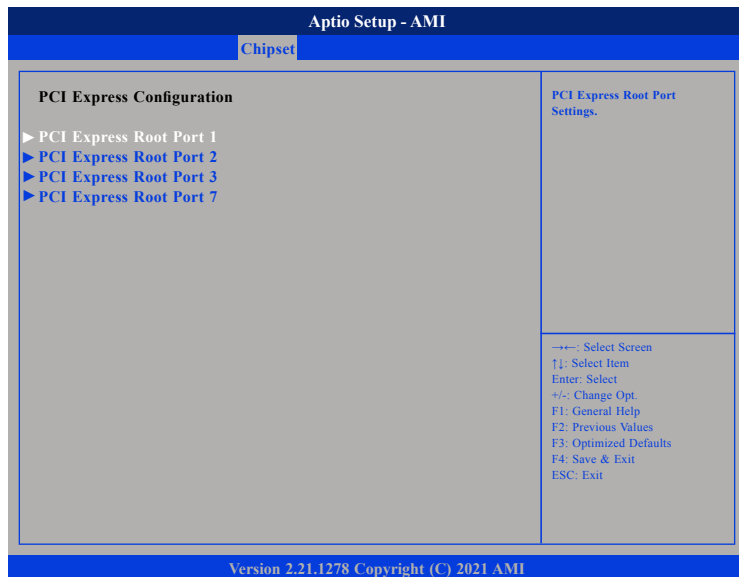

PCI Express Root Port 1, 2, 3 and 7

Settings for PCI Express root port 1, 2, 3 and 7.

PCI Express Root Port 1, 2, 3 and 7

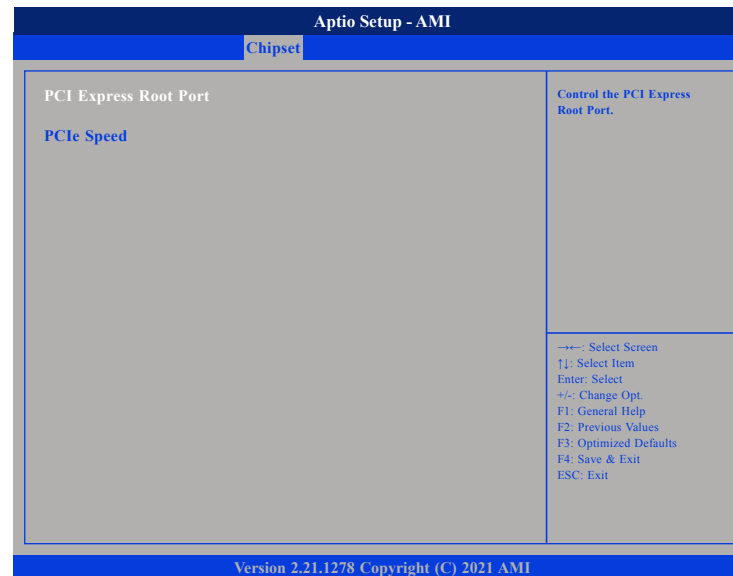

PCI Express Root Port

Enables or disables the PCI Express port.

PCIe Speed

Configures the speed of the PCI Express Root Port.

SATA Configuration

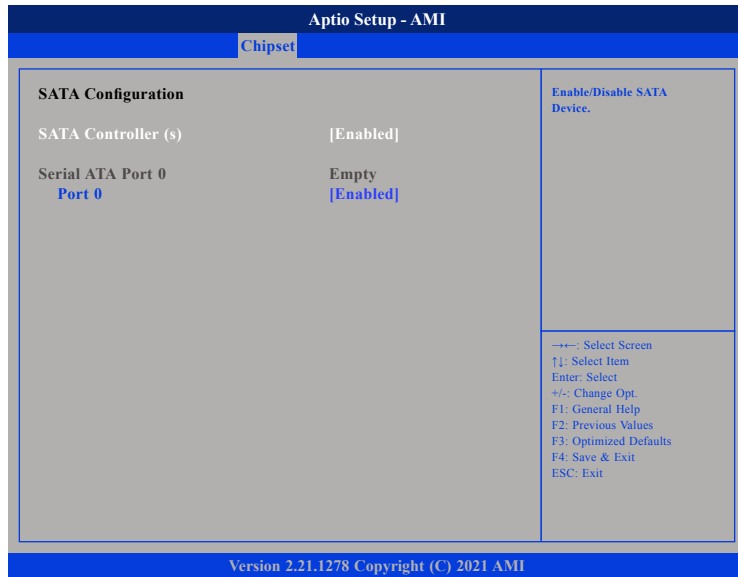

SATA Controller(s)

Enables or disables the SATA controller.

Security

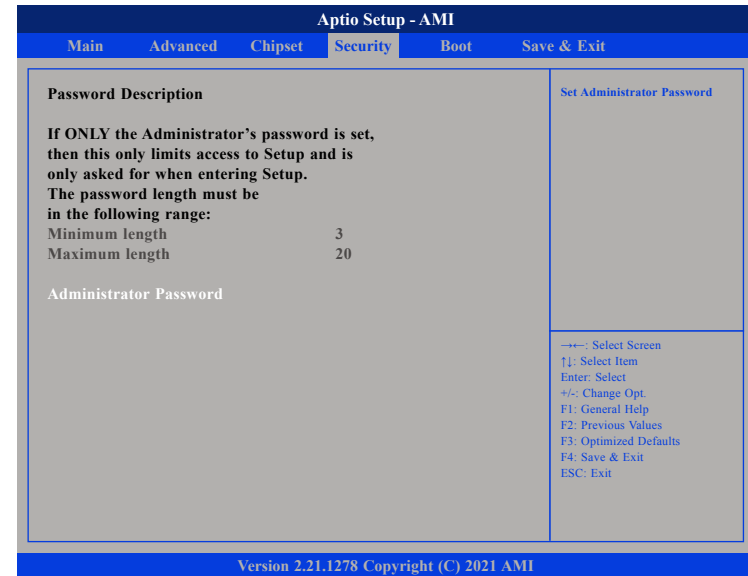

Administrator Password

Select this to reconfigure the administrator's password.

Boot

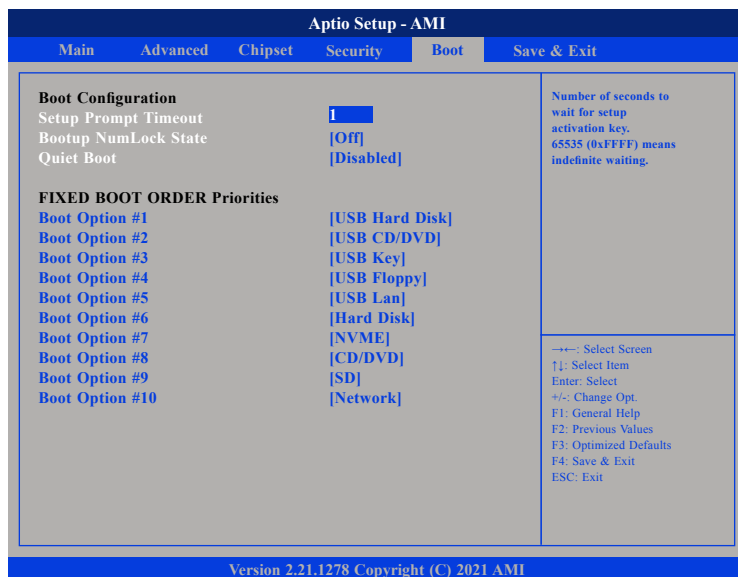

Setup Prompt Timeout

Selects the number of seconds to wait for the setup activation key. 65535(0xFFFF) denotes indefinite waiting.

Bootup NumLock State

This allows you to determine the default state of the numeric keypad. By default, the system boots up with NumLock on wherein the function of the numeric keypad is the number keys. When set to Off, the function of the numeric keypad is the arrow keys.

Quiet Boot

Enabled Displays OEM logo instead of the POST messages.
 Disabled Displays normal POST messages.

Fixed Boot Order Priorities

Adjust the boot sequence of the system. Boot Option #1 is the first boot device that the system will boot from, next will be #2 and so forth.

Save & Exit

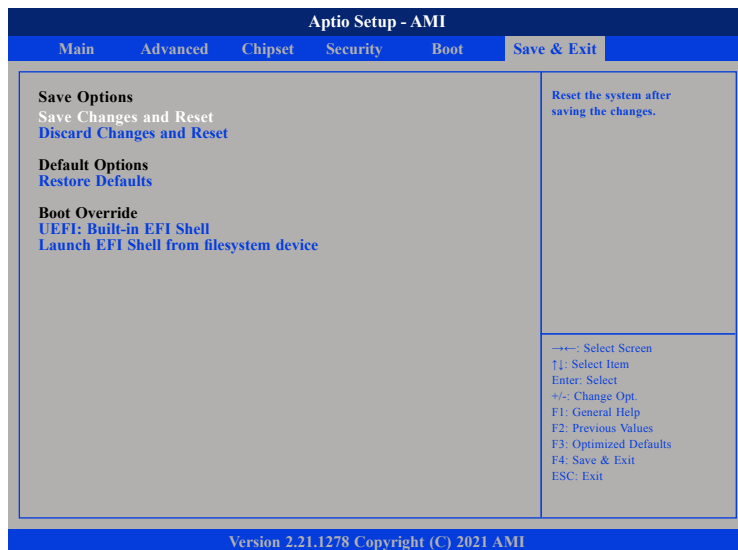

Save Changes and Reset

To save the changes and reset, select this field then press <Enter>. A dialog box will appear. Confirm by selecting Yes.

Discard Changes and Reset

To exit the Setup utility and reset without saving the changes, select this field then press <Enter>. You may be prompted to confirm again before exiting.

Restore Defaults

To restore the BIOS to default settings, select this field then press <Enter>. A dialog box will appear. Confirm by selecting Yes.

Boot Override

To bypass the boot sequence from the Boot Option List and boot from a particular device, select the desired device and press <Enter>.

Launch EFI Shell From Filesystem Device

Launches the EFI shell.